

# MENDIPS Raceway

*Thunder in the Hills!*

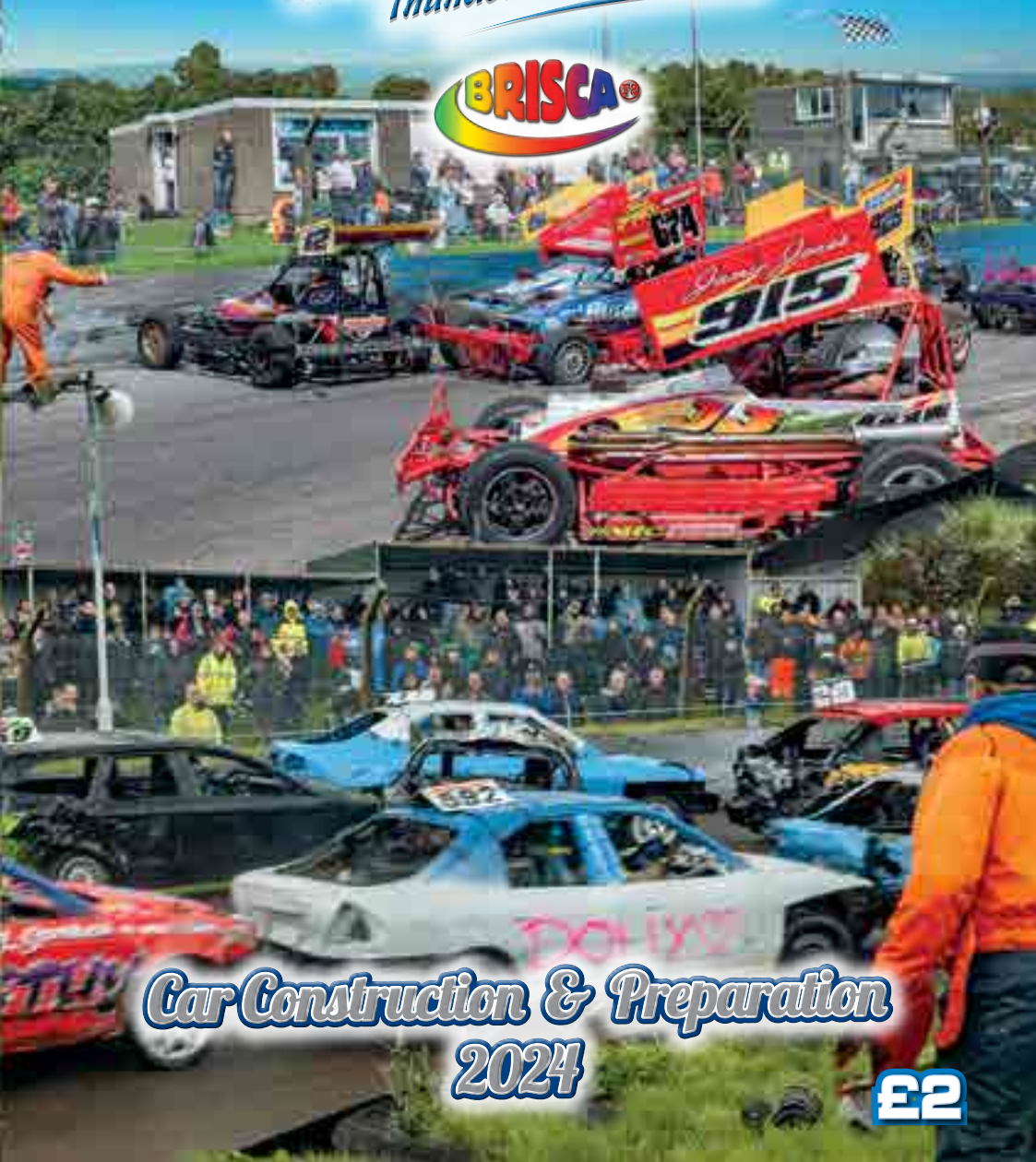

**Car Construction & Preparation  
2024**

**£2**

Mendips Raceway is operated by  
Graham, Pat and Jack Bunter for  
Mendips Raceway Ltd,  
Nylands,  
Charlton Horethorne,  
SHERBORNE,  
Dorset,  
DT9 4NG

Tel: 01963 220028  
e mail: jack@mendipsraceway.com  
website: www.mendipsraceway.com

This the address for all enquiries concerning the Raceway.

Racetrack operation depends very much on the cooperation of our neighbours.

With this in mind:

- NEVER block farmers gateways with cars or trailers.
- NEVER unload your car in the lane outside the stadium.
- NEVER drive your car on the lane outside the stadium.
- NEVER leave rubbish or parts of cars outside or inside the stadium.
- ALWAYS remember: lots of people would like the track closed, so don't give them any opportunity to complain.

These regulations issued January 1<sup>st</sup> 2023 and cancel all previous issues.

Index:

Page 1	Rules of Racing
Page 6	National Banger Rules and Regulations 2023
Page 33	Rookie Banger Rules
Page 36	Back to Basic Banger Rules
Page 40	Special Rod Rules
Page 44	Junior Rod Rules
Page 47	Reliant Robin Rules



# 2024 Driver Safety Equipment Specification (DSES) Regulations

## v2024.01 (*Published*)

### Issued: 19<sup>th</sup> January 2024

- 
- Note (Additions): Text highlighted in **bold, red, italics**, indicates a change from the previous version of these regulations.
  - Note (Removals): Text in ~~grey strikethrough~~ indicates a regulation or text that is no longer applicable (with immediate effect, unless noted), and will be subsequently removed in the next major release of these regulations.
- 

#### Definitions Used in These Regulations

DSES	Driver Safety Equipment Specification (these regulations)
FHR	Frontal Head Restraint (including HANS®, Hutchens®, Defender® and similar type devices)
BORSE	British Oval Racing Safety Executive (historical body, not currently active)
Junior Drivers	Drivers aged 15 and under
Adult Drivers	Drivers aged 16 and over
Racecar	The vehicle, used by a driver in a race. Commonly this vehicle is car derived, but for the purpose of these regulations it is taken to also include karts, vans, coaches, or other specialist vehicles sanctioned by the promoter or the ORCi for a licensed event.

#### General Notes

- It is the **driver's responsibility** to ensure that they and their team comply with all (DSES) Regulations **at all times** (including scrutineering, practise, and racing).
- Any necessary changes to the DSES Regulations during the course of a season will be notified to drivers through the official ORCi / WatchItRaceIt website ([orci.co.uk](http://orci.co.uk) / [watchitraceit.co.uk](http://watchitraceit.co.uk)), and may additionally be notified to drivers through individual formulas' own official communication channels. Change advisories received from any other source should be checked against these official sources for authenticity and accuracy.
- Proposals for any change(s) to the DSES Regulations **MUST** be submitted in writing to the ORCi through one of the following channels:
  - Mail: ORCi Secretary, PO Box 567, Stevenage, SG1 9QD
  - Website: Use the online contact form at <http://www.orci.co.uk/contact>
  - Email: [safety.rules@orci.co.uk](mailto:safety.rules@orci.co.uk)
- Proposed changes will be considered by the ORCi and an official response duly made as appropriate.
- Drivers must **NOT** use items, or make modifications to existing items, that do not meet the current DSES Regulations, whether they believe they have a case for them or not. A process to request a change of the regulations to permit such items or modifications exists, and should be followed by all drivers.

## 900 General

- 900.01** All DSES Regulations apply to all drivers in all ORCi and ORCi-affiliated formulas unless otherwise stated.
- Where the carrying of one or more authorised passengers in a racecar is sanctioned at an event, and would require the driver to wear/engage their mandated safety equipment, e.g. 2-seater ride-along demonstrations, then these regulations apply equally to the passenger(s) as they do the driver.
- 900.02** All driver safety equipment must be worn/engaged at all times when on track during racing, practise, test, time-trial, exhibition, or demonstration sessions.
- 900.03** The manufacturer's and homologation identification marks on all safety equipment MUST remain visible as originally produced.
- 900.04** Where an ORCi official is unable to determine the conformance of any safety equipment item to these regulations, or an item is identified as not being in conformance, the ORCi reserves the right for an official to refuse use of the item until such time as its conformance can be determined, and/or retain the item for the duration of the event.
- 900.05** It is the responsibility of the driver to maintain and care for their safety equipment in an appropriate manner, and in accordance with any instructions issued by the manufacturer(s).
- 900.06** It is the responsibility of the driver to ensure their safety equipment is fit for the intended purpose since significant damage could be sustained without this being apparent to any official.

## 901 Helmets and Goggles/Visors

### 901.01 Helmets

**901.01.01** A helmet conforming to at least one of the permitted standards detailed below MUST be worn.

**901.01.02** Helmets MUST meet or exceed the MINIMUM standard as directed by the ORCi (previously undertaken by BORSE).

The current permitted helmet standards for all drivers are:

- FIA 8860-2010
- FIA 8859-2015
- FIA 8860-2018
- FIA 8860-2018 ABP
- Snell SA2010
- Snell SAH2010
- Snell SA2015
- Snell EA2016
- Snell SA2020
- SFI Foundation 31.1A
- SFI Foundation 31.2A
- SFI Foundation 31.1
- ECE R22.05
- ECE R22.06

The following helmet standards are permitted for Junior drivers only in addition to those above:

- Snell CMR 2007
- Snell CMS 2007
- Snell CMR 2016
- Snell CMS 2016
- SFI 24.1

**901.01.03** The helmet MUST fit the driver correctly, referencing the manufacturer's sizing/fitting guidelines.

**901.01.04** All helmets MUST display the green "ORCi 20 Approved" serial-numbered helmet sticker, as per Illustration 01 below. Older green 2019, blue 2015, and red 2010 stickers are NOT valid (Illustrations 02, 03 and 04).

- A dated ORCi sticker indicates only that a helmet was manufactured and homologated to one of the permitted standards listed above.
- Where a helmet is presented for a pre-meeting safety check without the appropriate ORCi dated sticker, it will be inspected by a scrutineer or appropriate official, and, if homologated to one of the permitted standards above, it will either be:
  - (a) Stickered with the current ORCi dated sticker and accepted for use (subject to basic checks for obvious signs of significant damage), or,
  - (b) Temporarily accepted for use (subject to basic checks for obvious signs of significant damage) pending the application of an ORCi dated sticker at a later date by an appropriate official.



# 2024 RULES OF RACING

Version 2024.01

## REVISED RULES FOR 2024 IN RED PRINT ITEMS MARKED STRIKETHROUGH ARE NO LONGER PERMITTED

### GENERAL

The following rules will apply to all formulas that race at ORCi Sanctioned Tracks. Any variation to these rules must be agreed with the Oval Racing Council, and then, only in exceptional circumstances.

**At all times while at a race meeting, a driver shall be deemed to be under Racing Rules. Any driver guilty of any act prejudicial to the sport, including comments on social media sites etc, shall be reported to the appropriate Board of Control or Formula Organiser, for disciplinary action, and may be called upon to appear before the Board or Control or Formula Organiser, to answer the charges.**

The interpretation of these rules pertaining to race procedures or lap scoring positions will be decided by the appointed ORCi officials at the race event.

### STARTING POSITIONS

Drivers must start in positions laid down by the Steward of the Meeting and in their correct grade (where applicable) at all times. Special dispensation to start at the rear of the grid will be made, only on application to the Steward of the Meeting, in the case of a driver wishing to test a new car on the occasion of its first meeting or at the Steward of the Meeting's discretion.

### CLUTCH STARTS

At all clutch starts the Start Marshal shall satisfy himself that all drivers are ready on the red flag and are in a position where they can see the start signal before dropping the green flag.

Any driver moving before the green drops will be liable to immediate exclusion.

### ROLLING STARTS

In the case of a rolling start the drivers shall drive a preliminary lap, or part lap as directed by the Steward of the Meeting, keeping abreast in their proper positions and at a speed set by the inside driver at the front of each grid and/or grade and shall maintain the allotted gap between grades where applicable.

Where a pace car is used, it is the pace car that sets the pace and the lead car must keep the gap of between 3-4 car lengths between itself and the pace car, until the green flag.

The race shall be started by the Start Marshal causing the starting flag to be dropped at any time after the leading cars have passed the 4th bend. The lead car may slowly increase speed between bends 3 and 4.

All drivers must keep rank, and must wait for the starting flag before commencing racing.

No car must accelerate beyond the rolling lap speed set by the lead car until the Start Marshal has shown the starting flag.

Any car unable to maintain the pace lap order due to clutch problems must start between the leader and the last car in order to avoid upsetting the start / restart.

Prior to the start, or re-start, a driver being too far in front or reducing speed on approaching the starting line, may be excluded or docked places at the discretion of the Steward of the Meeting.

### START AND FINISH POINTS

The start and finish of a race or an attempt at a record shall occur when any part of the car passes over the starting or finishing line. In the event of a blocked track, the finishing line shall be deemed to extend a reasonable distance in to the infield. In formulas where transponders are used, the Steward of the Meeting's decision is final.

### RACE PROCEDURE and DISCIPLINE

No work may be carried out on any car at any time on the race circuit without the permission of the Steward of the Meeting. This permission may be communicated via the Clerk of the Course. If a driver wishes to carry out work on a race car and that work can be completed within the regulations specified in these rules, the car must first be removed to a safe area within the arena. The driver must not under any circumstances, leave the confines of the race circuit during a race to perform this work.

After the first green flag of a race has been displayed, any car, having entered that race or any re-run/restart thereof, cannot receive attention from anyone other than the driver and then only when this can be achieved without assistance, i.e. the handing of tools or parts over the safety fence / the carriage of spare parts or tools within the race car / the use of implements from within the arena whether they be part of another car or stadium items is forbidden. It is not permitted to transfer parts from a disabled car within the arena.

In the event of cars becoming entangled, the track staff are permitted to disentangle them during a caution or stoppage and permit them to rejoin at the discretion of the Steward of the Meeting at the rear of the re-formed grid – this is not considered to be 'outside assistance'. In all cases the primary cause(s) of the suspension/stoppage, shall

be excluded for any re-run or re-start of the race and may be officially disqualified from the race.

In addition, cars being push started will not be deemed as outside assistance provided they were not the cause of the caution or stoppage.

Please note that after the first green flag of a race, no additional cars are allowed to take part even if the race is a complete re-run. In addition, a car will only be eligible for the re-run/re-start if it was part of that particular race suspension or stoppage.

Drivers who use their car to shield and protect an upturned or damaged car, will not be excluded when the race resumes at the discretion of the Steward of the Meeting, and whenever possible will be re-gridded accordingly.

Please note that the above Race Procedures may be varied via Supplementary Championship Regulations. These are only applicable to the following Championship races: World, British & European. The Supplementary Championship Regulations must be submitted to the ORCi Secretary at least 14 days prior to the event and will be published on the ORCi website and any formula specific website. The regulations must also be circulated in writing to all competitors within the event.

## **SIGNALS**

The following flag signals will apply in all races unless otherwise stated. At some tracks traffic lights may be used to further emphasise the flag signals. The Start Marshal, Steward of the Meeting and Flag Marshals shall apply the following rules to the use of flags during racing:–

The **GREEN FLAG** indicates the start of the race and will remain until all competitors have passed the start line.

The **YELLOW FLAG** indicates danger as described below.

- a) During the rolling lap the Start Marshal will show a yellow flag (covering the green flag).
- b) The Start Marshal will begin the race by showing the GREEN FLAG.
- c) (b) Waved yellow flag i.e. Race Suspension:

A Flag Marshal, wishing to inform the Steward of the Meeting of a serious incident or the presence of hazardous objects or material on the track shall do so by using their radio and/or an 'open' yellow flag held above their head, whereupon the Steward of the Meeting may introduce a Race Suspension. Co-ordination between the Steward of the Meeting, Start Marshal and Flag Marshals in these circumstances is critical.

In the event of a major incident (which includes a car rolling onto its side or roof on the track and in the line of racing) or where loose objects or material on the track may constitute a hazard to spectators, competitors or officials, the Steward of the Meeting may bring the whole circuit under **RACE SUSPENSION** conditions, without the race being stopped (red flagged) by introducing waved yellow flags.

In the event of a wheel becoming detached from a car, immediate race suspension will be invoked.

On introduction of a race suspension. **ALL CARS MUST SLOW TO ROLLING LAP SPEED** (or stop where the lead car is so instructed) and get into single file. **THERE WILL BE NO OVERTAKING**. In some circumstances it may be necessary to bring the single file grid to a temporary halt under a race suspension (for example, to ease the movement of recovery/rescue vehicles). Such a temporary halt does not constitute a Red Flag Stoppage. Any driver unlapping them self or breaking rank from the single file, without authorisation, will be immediately excluded from the restart of the race. In this situation, drivers are not permitted to leave the seat of their cars or have anyone touch their car.

It is essential that drivers are aware and make their mechanics aware that they will be excluded should their mechanics enter the arena at this time whether or not they receive assistance. Cars must restart in the same condition as before the Race Suspension. In certain circumstances for safety reasons, the Steward of the Meeting may authorise an official to remove metal etc from a car during a race suspension. In this case this is not considered to be outside assistance.

Restart Order (see Table 1)

Cars will be lined up, in preparation for the restart, in the on-track order prevailing prior to the race suspension (yellow flags) or race stoppage (red flags). Any lapped cars in-between those occupying the top six positional places in the race will be sent around the track, in the direction of racing, to the rear of the grid, and will be credited with regaining one lap back in the race. If a driver occupies a place in the top six but is a lap(s) down on the leader they will gain a lap by being sent to the back of the grid but will not have the backmarking drivers removed between themselves and the other front runners. No driver will gain more than one lap back in the race. This means that when the race is restarted at least the top six cars (provided they are all on the lead lap at the time of the stoppage) will be in positional order on the track without any back-markers in between.

A driver must NOT un-lap themselves unless instructed to by an official. Any driver un-lapping themselves without permission will be liable to exclusion from the restart.

Incorrect Exclusion

The Steward of the Meeting is empowered to re-instate any driver being, in their opinion, incorrectly taken out of the race during a suspension or stoppage.

During a rolling Race Suspension, manual lap scoring is suspended, and electronic lap scoring will utilise the 'non-counting' yellow flag system, to ensure that the appropriate number of racing laps are raced.

The race can only be restarted by the Start Marshal showing the green flag to the Race Leader. The green flag will be withdrawn after all cars have passed the Start Marshal.

The **RED FLAG** is used to denote that the race has been stopped. All drivers must, with care, slow down immediately and STOP as soon as possible (recommended within one quarter of a lap). Cars will then remain stationary, to neutralize the track, until the Clerk of the Course gives instruction to reform on the grid or leave the track, (see rule STOPPAGES). Failure to comply with a red flag will result in exclusion, at the discretion of the Steward.

The **CHEQUERED FLAG** indicates completion of the required number of laps. It will be the intention for all races to be run to their full published distance, wherever possible. The Chequered Flag shall be waved at the first driver to complete the race distance and held out until cars for paid and/or points places in the race have completed the race distance. Drivers having received the Chequered Flag must continue at race speed until the red flag in conjunction with the chequered flag is displayed, otherwise they may incur a penalty. Race conditions and rules apply until the red flag is shown with the chequered flag.

**RED & CHEQUERED FLAGS (waved together)** means the end of the race. All cars to slow down with care, to make their way to the Pit Gate. Any offence committed on track after this time will render the driver liable to a penalty.

The **BLACK FLAG** is shown to a car that has been disqualified and which must retire from racing immediately to the infield, with care.

The **BLUE FLAG** indicates to a driver that they must hold their line (inside or outside) as there is a much faster car behind that is trying to overtake. (Non Contact Formulas only). This flag will be given to a driver a maximum of 3 times. If the blue flag has been waved on consecutive laps for a maximum of 2 laps, on the third lap, if the driver has failed to comply the BLUE & WHITE STRIPED flag will come into effect. A **BLUE & WHITE STRIPED** flag will be shown which will indicate that the driver must give up their position to the car behind. Failure to do this will result in a black flag being shown – driver disqualified.

The **WHITE FLAG WITH a RED CROSS (X)** is a TECHNICAL DISQUALIFICATION FLAG. This is used to signal to a driver that they have a problem with their car and must immediately retire to the infield, with care.

The **WHITE FLAG OR BOARD, WITH BLACK CROSS (X)** advises the driver that they are under observation for a potential infringement, and that they may be penalised at the end of the race.

The **WHITE FLAG WITH BLUE SPOT**. Used to warn drivers that there is oil or slippery fluids on the track. However racing may continue.

A **LAP BOARD** indicating the number of laps remaining to be completed must be displayed by the Start Marshal over a minimum of the last three laps.

### **STOPPAGES (Red Flag)**

A race may only be stopped on instruction from the Steward of the Meeting, in the interests of safety or other contributory factors (Time Limit) etc. It shall be the intention, whenever possible, to run all races to a conclusion over the published race distance. The Promoter reserves the right to call a result AT ANY TIME.

The race may be stopped if the pits gate has to be opened to facilitate entry to the track of either an ambulance or breakdown vehicle, although this can also be done under a yellow flag at the Steward of the Meeting's discretion.

- a) If any race is stopped after the first 3 laps then the race shall be restarted and run over the balance of laps outstanding to the leading car.
- b) Restart Order (see Table 1)  
Incorrect Exclusion  
The Steward of the Meeting is empowered to re-instate any driver being, in their opinion, incorrectly taken out of the race during a suspension or stoppage.
- c) In the event of no cars having completed more than 3 laps of the total distance, the race shall be re-run. Note that a temporary halt under yellow flags (caution) is not the same as a stoppage under red flags.
- d) The only cars permitted to take part in any re-run shall be those having taken part in any/all other restart(s) immediately prior to the stoppage. A car missing taking part in a restart shall not be eligible to compete in any subsequent restart of the same race.
- e) A driver is permitted, with the permission of an official, to leave his car during a red flag period, but any work performed must be authorised by the Steward of the Meeting.

### **SAFETY**

It is an offence for a driver to push, or work on his car within the arena while a race is in progress. It is the driver's responsibility to ensure that current health and safety legislation is adhered to when in the pits area.

Tyre buffing is allowed only by the use of a manual surform (the wheel/tyre must be still), i.e. not mechanically turning. **The buffing of tyres in the pits on an electric motor or running on a car is strictly forbidden.**

**The speed of any vehicle when not in race mode is safe walking pace at all times (some circuits will implement the use of a Pace Car to control this speed)**

## **DISQUALIFICATION and PENALTIES**

Drivers will be penalised (and may be disqualified) for unnecessarily cutting across the infield or for gaining advantage by leaving the track to pass an opponent. A penalty will be imposed for:-

- a) Unnecessarily cutting across the infield.
- b) Gaining advantage by leaving the track to pass an opponent. This will include the illegal use of kerbs.
- c) Breaking the rolling lap to gain advantage either by gaining places or by deliberately holding up the start.
- d) Leading a Start or Re-Start at too fast a speed.

A driver suffering a flat tyre may receive a technical disqualification (see above) at the discretion of the Steward of the Meeting, having due regard to the number of laps still to run.

If a driver is penalised for more than one incident during a race or a meeting, the Steward of the Meeting may, at their discretion, disqualify the driver from the rest of the meeting and/or report the driver to the Board of Control or Formula Organiser.

The offending driver may be fined or suspended from driving at future meetings, the amount and period to be decided by the appropriate Board of Control or Formula Organiser.

If a driver, convicted of an offence has a period of their ban suspended, that suspended ban is automatically triggered if the driver is found guilty of an offence of the same nature – i.e. On Track/Racing; Technical; or Behavioral.

## **FENCING**

Different classes of oval racing may have their own formula-specific rulings on Fencing.

## **END OF RACE**

A race shall be deemed ended when the cars for paid and/or points places in the race have completed the race distance. Drivers must continue racing until the Red and Chequered flags are displayed together before slowing down. They must not slow down when only the chequered flag is shown. Drivers who do this may be penalised.

## **INTERPRETATION OF RULES**

Decisions of Officials on interpretation of the rules pertaining to race procedures or lap scoring positions, shall be considered Final. At all times, while on the track, a driver shall be deemed to be under Racing Rules.

## **AGE LIMITS**

### **Junior Formulas**

In Junior Formulas the upper and lower age limits are set by the organising Promoter or Association. I.e. in ORCi Ministox the lower age limit is 11 years and drivers must leave the formula prior to their 16th Birthday.

Other junior formulas may have other upper and lower age limits determined by the organising ORCi Promoter or Association.

NB. All drivers under the age of 18 years must have their Licence Application guaranteed by the parent or legal guardian - proof of guardianship may be required.

### **Senior Formulas - Lower age limit**

All competitors in a Senior Formula must complete a Medical Self Declaration which is included in their Licence Application Form.

In all Senior Formulas the minimum age for competitors is set at 16 years. No competitor may participate in a Senior Formula prior to their 16th birthday.

NB. All drivers under the age of 18 years must have their Licence Application guaranteed by the parent or legal guardian - proof of guardianship may be required.

### **Senior Formulas - Upper age limit**

All competitors in a Senior Formula must complete a Medical Self Declaration which is included in their License Application Form.

Drivers who reach the age of 55 may, in certain formula, be asked to pass a Medical Examination conducted by their General Practitioner (GP) before applying for their License. Subsequent annual License applications do not require these Medical Examinations up to the age of 65 unless specifically requested by the ORCi.

All ORCi sanctioned Senior Formulas require drivers to pass a Medical Examination when applying for their License at the age of 65 years and over on an annual basis.

Any fees due for these Medical Examinations must be paid by the applying driver. The Medical Examination should



be carried out to a standard similar to that required for Life Insurance. Competitors holding a current HGV license may use this as proof of Medical Condition.

Applications for a License by competitors over 55 years of age who have not held a license in the previous 5 years in the same or similar formula would not normally be granted.

In all cases the ultimate decision as whether a driver may hold a Competition License resides with the ORCi Promoter or Association.

### **Drivers and Smart Devices**

Drivers should be wary of any Smart devices on their person during racing. Some have impact and distress technology built into them, which could trigger responses from Emergency Services. These should not be worn during racing or mode switched off.

## **FREQUENTLY ASKED QUESTIONS**

### ***What should I do if I am stationary on track during a race?***

Firstly, look out for a marshal and signal that you are not injured with a "thumbs up". If you are injured and need assistance give the thumbs down signal, if possible. If eye contact is made with the marshal, and no signal is given, then the marshal will assume that you're injured and this information will be relayed to race control.

Should the Steward in Race Control believe you are stationary in a dangerous situation they may stop the race even if you are not injured.

Any driver who is the cause of a caution or stoppage cannot take part in the re-run. Drivers who sustain injury or suspected injury must be passed fit by the medical team in order to take further part in the event. Drivers who feign injury in order to get a race stopped will be loaded up from the event.

During a race, whilst on track or on the infield, you must not exit your car and you must keep your harness and helmet on at all times. The only exception to this is when you are in extreme danger within the car, for example in the case of fire. In this case you must exit the car with extreme care, always remembering that there is a danger of other competitors on track. You should then make your way to the nearest Safe Area. These designated 'Safe Areas' will be identified at the driver's pre meeting briefing or written Drivers Instructions.

In the event of race suspension or stoppage, the following rules will be applied in context of the formula or event type:

Racing formulas:

When the yellow flag is shown and cars are halted, drivers must wait for the Clerk of the Course or Senior Race Official to attend the scene of incident. At this time, with permission from the Official in attendance, may they ask to leave their car. This is subject to the Clerk of the Course in conjunction with the Steward of the Meeting. If permission is granted by the Clerk of the Course, the driver must leave their car as quickly as possible and move to the Safe Area or away from the Raceway, the driver must not delay checking for damage once they have been released from their car.

Banger formulas:

Yellow flags are not used within National Banger formats unless a car's driver's door is facing the racing traffic or if a request is made by a Clerk of the Course or Steward of the Meeting to prevent a car from being hit. In this instance, a driver maybe penalised for failure to comply to the use of a yellow flag application if they attack a car covered by this rule.

If a race is stopped by use of the Red Flag, unless the driver is in immediate danger, the driver must remain within the car. The Clerk of the Course or Senior Race Official will attend the scene of incident when safe to enter the Raceway and attend to issue which causes the Red Flag. If a driver wishes to leave their car for whatever reason, the Clerk of the Course or Senior Official in attendance must grant them permission before leaving the car. They must then proceed to the Safe Area, wherever this may be designated by the staging promotion.

All Formulas:

In an instance where a driver is not a part of the cause of stoppage, but may wish to leave their car, the driver must attract the attention of one of the Safety Marshals. In doing this, the Safety Marshal should then ask the Clerk of the Course or Senior Race Official to attend the car. A Safety Marshal does not have permission to release a driver. It must be done by a Clerk of the Course, Senior Race Official or Steward of the Meeting.

Once the first Green Flag is shown, all drivers must continue to wear their PPE, remaining strapped in their cars for the duration of the race. The end of the race is defined by the showing of the Red Flag after the Chequered Flag. A driver must wear all their PPE until he/she has left the arena or to exit the car in an emergency such as fire or as instructed by an official.

### ***What should I do if I need to stop my car because of mechanical failure during a race?***

Retire to the Infield as soon and as safely as possible. When you have retired to the infield, remain in your car,

keeping your harness and helmet on. You must not get out of your car even under yellow or red flag stoppages, just remain in your car, until the end of the race.

**Table 1 – Restart Orders**

The letters A, B, C, etc identify an individual driver.

The numbers 10, 11 identify the number of laps completed.

**Race in which there are AT LEAST 6 drivers on the lead lap**

On track order at time of yellow flag

Front	A11	B10	C11	D11	E10	F11	G11	H11	I11	J10	K11
-------	-----	-----	-----	-----	-----	-----	-----	-----	-----	-----	-----

Restart order

Front	A11	C11	D11	F11	G11	H11	I11	J10	K11	B11	E11
-------	-----	-----	-----	-----	-----	-----	-----	-----	-----	-----	-----

**Race in which there are NOT 6 drivers on the lead lap**

On track order at time of yellow flag

Front	A11	B10	C11	D11	E10	F11	G11	H10	I10	J10	K10
-------	-----	-----	-----	-----	-----	-----	-----	-----	-----	-----	-----

Restart order

Front	A11	C11	D11	F11	G11	H10	I10	J10	K10	B11	E11
-------	-----	-----	-----	-----	-----	-----	-----	-----	-----	-----	-----

# 2024 ORCi NATIONAL BANGER SPECIFICATIONS



## SECTION 1:- UNLIMITED CC NATIONAL BANGER SPECIFICATIONS

### CONTENTS

• TYPE OF CAR PERMITTED FOR USE .....	2
• STRIPPING & PREPARATION.....	2
• ROLL BAR .....	2
• STRENGTHENING & PREPARATION.....	3
• FUEL SYSTEM.....	5
• ELECTRICAL SYSTEM .....	5
• COOLING SYSTEM .....	5
• ENGINES, GEARBOX & PROPSHAFTS .....	6
• EXHAUST & EXHAUST MANIFOLDS.....	6
• CARBURETTOR / INLET MANIFOLD.....	6
• SUSPENSION, BRAKES & AXLES.....	7
• DIFFERENTIALS .....	7
• WHEELS .....	7
• TYRES .....	7
• SAFETY EQUIPMENT.....	8
• SEATS.....	8
• NUMBERS .....	8
• ROOF GRADES.....	8
• FINAL PREPARATION .....	9

## SECTION 2:- NATIONAL BANGER SPECIFICATIONS EXCLUDING UNLIMITED

### CC

### CONTENTS

• TYPE OF CAR PERMITTED FOR USE .....	10
• STRIPPING & PREPARATION.....	11
• ROLL BAR .....	11
• STRENGTHENING & PREPARATION.....	12
• FUEL SYSTEM .....	14
• ELECTRICAL SYSTEM .....	14
• COOLING SYSTEM .....	14
• ENGINES, GEARBOX & PROPSHAFTS .....	15
• EXHAUST & EXHAUST MANIFOLDS.....	15
• CARBURETTOR / INLET MANIFOLD.....	15
• SUSPENSION, BRAKES & AXLES.....	16
• DIFFERENTIALS .....	16
• WHEELS .....	16
• TYRES .....	16
• SAFETY EQUIPMENT.....	17
• SEATS.....	17
• NUMBERS .....	17
• ROOF GRADES.....	17
• FINAL PREPARATION.....	17

## SECTION 3:- GENERAL RULES OF RACING



# **2024 NATIONAL BANGER SPECIFICATIONS**

## **UNLIMITED cc**

### **REVISED RULES FOR 2024 IN BOLD/ITALIC/RED PRINT**

### **ITEMS MARKED ~~STRIKETHROUGH~~ ARE NO LONGER ALLOWED**

**These rules are valid from January 1<sup>st</sup> 2024**

**The overriding principle of these regulations is that unless it is stated that you can do it, you must work on the principle that you CANNOT.**

#### **TYPE OF CAR PERMITTED FOR USE**

- You must use any Rear Wheel Drive four wheel saloon, coupe, estate car or people carrier.
- No SUV's, 4 x 4 or van derived (e.g. SsangYong Rodius) vehicles allowed.
- The MOT Brake Weight Chart maybe used to determine which cars are eligible for the unlimited cc class as follows. (1360kg - over)
- Front wheel drive American cars maybe permitted with prior permission from the staging promotion only
- Chrysler Imperial chassis cars are NOT permitted for use.
- The Toyota Previa is permitted for use but must run on a radiator which must be fitted in front of the engine and in the engine compartment. The rear suspension must be lowered to an average 410mm bumper height.
- As from 3 April 2017 the SsangYong Rodius is not permitted for use.
- Cars that would be unsuitable for racing due to age/corrosion or style, may be allowed to race with the Staging Promoter's permission for welding repairs to make it track worthy.
- It is permitted to change all wheel drive cars to rear wheel drive using car derived parts only
- **FWD American cars may not be converted to RWD.**
- **Convertibles may not be used.**

#### **Special Meetings**

- Your promoter will state either via the fixture list or special entry form at which meetings this rule can be used and therefore cannot be used by a driver regardless of type of car at a normal meeting!!
- Promoters may run special meetings for a certain type of vehicle e.g. 7.5 tonnes vehicles, SUV's, 4 X 4's, Reliant Robins, Coaches etc, for which rules will be issued by the Staging Promoter. Left hand drive vehicles may be permitted at the promoter's discretion – this should be checked in advance with the staging promoter.

#### **STRIPPING & PREPARATION**

- It is compulsory to remove all the interior, glass, airbags and charges, spoilers and side-skirts.
- Hearses must have roof rails removed
- The complete dashboard must be removed.
- Remove all seats except the driver's which must be retained, the use of a racing seat is not allowed. **Seats with airbags must be deactivated.**
- Remove spare wheel carriers and tow bars plus associated steelwork if fitted.
- Original fuel tanks must be removed. If however, the tank is an integral part of the body you must remove as much as possible.
- You may use the original standard steel bumper.
- A steel plate maximum 3mm (1/8") thick and 100mm (4") wide may be fixed to the front of the chassis rails/front crossmember, must not return down the chassis rails more than 180mm (7") and may be fixed by a maximum of 5 bolts, and no welding is allowed.
- The standard bumper cannot be folded or flattened with exception of where the 3 bolts go through with maximum of 50mm washers.
- No wrap around bumpers allowed.

- Plastic on bumpers must be removed.
- No tape or seat belting allowed on bumpers.
- All cars with aluminium bumpers, excepting Yanks, must have the bumper and retaining irons removed before racing e.g. Volvo 2 series. You must fit a flat plate 100mm x 3mm in its place. This may be folded back a maximum of (180mm) with a maximum of two bolts per side & three bolts on the front. The bolts must go THROUGH the chassis and not UP the chassis. You may add a maximum three extra bolts on the front of the plate coming back through but not up the chassis.
- Cars with no front cross members are permitted to link the chassis members with a chain.
- Chassis rails CANNOT be cut/shortened on fresh cars, if the chassis is cut back due to rot or damage the front crossmember CANNOT be re-fitted, the 3mm X 100mm Bumper MUST then be fitted.
- Repair patches may only be of one thickness, to original spec, and not patched over previous patches

## • **ROLL BAR**

- You must fit a single "hoop" roll bar in support of the door pillars, securely bolted to the roof and floor with a minimum size M12 bolt and suitable washers. Recommended that rollcage uprights to be above head height before adjustment. It is compulsory to have two bolts in the uprights.
- On adjustable roll cages the bolt(s) governing the height of the roll bar must pass through the roll bar socket and the extension, and spacer between the roof and roll bar may not exceed 50mm (2").
- You must have a minimum of four bolts in the top and four in the bottom, with a maximum of eight in the bottom on each side, and equal in number on both base plates. The maximum size of the base plate is 15" (385mm) x 11" (280mm) and base plates cannot be connected to each other over the tunnel. The plate may go up the side of the sill or straight up the rear panel up to a maximum of 4" (102mm) high. This must be the same length and width as the base plate/floor plate of the cage. A maximum of two bolts are permitted through the side.
- Roll cages may be adjustable (height/width), however the use of screw adjusters i.e. acrow style, are not permitted. Holes for adjustment must be at least 25mm apart, and two bolts per side must be used.

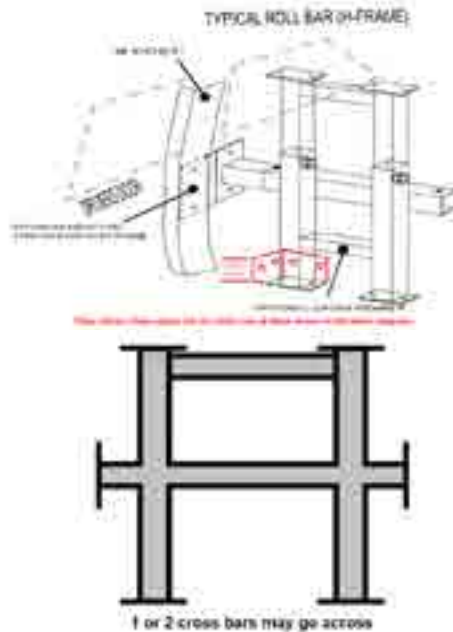

These two diagrams are a guideline to how the frame should be constructed but gusseting or triangulation is accepted.

- The roll cage must be fitted upright or dog-legged, but not leaning back or forward.
- It is compulsory to pad with foam - roll cages by the driver's head, B pillar and steering column.
- The hoop must be one piece, or two uprights and one top bar of a welded construction. This top bar should be as shown at the top of the uprights.
- A second cross bar is compulsory, a third is optional; these must be welded or bolted to the uprights.
- The Roll bar must not have any rear supports **or extensions** but may have **forward facing** extensions no further forward than the B post (see diagram) (this applies to both sides of the car). If used, this bolted through the B post.
- You may bolt the roll bar through both sides of the car.
- The minimum size steel for the roll bar is 2" (50mm) x 2" (50mm) RHS or tube equivalent, up to a maximum size of 4" (100mm) x 4" (100mm) ) RHS or tube equivalent. A minimum wall thickness of 3mm is required.
- Crossbars must have a 5" (125mm) square end plate fitted. This must be a minimum of 6mm thick.
- You must tie the seat at shoulder level to the roll cage or B pillar. This must be done through the seat frame and not the headrest; you may fit the 2<sup>nd</sup> cross bar in support of the seat just below the window aperture or weld a frame on the cage to support the seat at the top.
- **STRENGTHENING & PREPARATION**
  - Cars that fail pre or post-race scrutineering, found to be armoured or strengthened, including engine or gearbox suspension mounts that are over the top and not rectifiable on the day, will receive an immediate ORCi ban. If the vehicle can be rectified at the track then the vehicle must race, otherwise the driver will face an ORCi ban.

- If the Steward of the Meeting or the Promoter feels that the car is over built for strength this will result in an automatic 12month ban. For example, excessive welding or added steel work added to the car.

### **Doors & Door Plates**

- The driver's door may be welded but must have no additional strengthening (this includes gussets) other than steel RHS, which is allowed in the lower window aperture from A to B pillar of the drivers and rear driver's door, not extending further than the rear of the H frame. Please note that this is not allowed on the passenger side.
- A FLAT (no channel or angle) steel plate MUST be bolted over the driver's door to the following dimensions:
- **Height** – minimum 10" (255mm) to a maximum of 15" (380mm)
- **Thickness** - minimum 3/8" (9mm) – 3/4" (20mm)
- This must be fitted with a minimum of 3" (75mm) and a maximum of 6" (150mm) past the A & B pillars. This must be securely bolted with a minimum of four bolts.
- It is not permitted to cut slots in the driver's doorplate. Holes for bolts only.
- There must be at least one bolt through the A pillar and one through the B pillar or through the roll cage.
- The bolt size must be at least M16 studding or bolt. M12 is acceptable on all other bolts. For 2 door and pillar-less cars (no B Pillar), the door plate MUST be bolted through the roll cage.
- Door plates must extend past the rear roll cage upright.
- Door plates cannot be joined to the water tank in any way.
- All other doors must be secured by bolting, chains or seat belt webbing. The maximum number of bolts permitted is four per door. Where plates are used to secure doors (other than the driver's door), the plates must be a maximum of 12" x 12" (300mm x 300mm) – you may use ONE additional bolt per plate to secure through the A or B Pillar, this must be a minimum size 1/4" (6mm). **Passenger side plate inside washers must be maximum red 200x150mm and must not wrap around pillar.**

### **Driver's Floor Plate**

- A steel plate fitted to the driver's floor pan is compulsory. Floor plates may extend no further back than the front of the seat squab and must remain in the drivers footwell only and must be made of minimum 3mm steel.
- It must be no thicker than 6mm and must be bolted in only.
- Floor plates may extend up the side of the transmission tunnel to 150mm maximum, to the same height as the door sill, and up the bulkhead to within 200mm (8") of the top of the bulkhead, but the plate can only be bolted through the floor and the A-pillar only, not to the sill or bulkhead. You may put two bolts maximum in the gearbox tunnel with a maximum 50mm washer size.
- A 4" (100mm) steel plate no thicker than 6mm bolted through the A pillar to the door plate can be welded or bolted to the floor plate.
- A piece of steel (box section/channel/plate) may be used under the seat to link the roll cage to the rear of the floor plate. This must not exceed 100mm in width, 50mm in height and must be fitted with a minimum of 2 m16 bolts through the roll cage and 2 m16 bolts through the floor plate.

### **Bonnet/Boot**

- The driver must present their car for pre-meeting safety checks with the bonnet and bolts but they must NOT be fixed to the car.
- Triangular corner plates or straps may be used to secure the rear of the bonnet. They must be attached to the car by bolting or tack welding to a maximum of 1" (25mm) weld with a 1" (25mm) gap in between. Plates or straps must be placed no further than 20" (500mm) WELDING MUST NOT REACH THE 'A' PILLAR ON THE PASSENGER SIDE. All corner plates may be a maximum of 4mm thick.
- Bonnets must be bolted down using a maximum of four bolts, two bolts in either side of the bonnet. Maximum height of bolt above the washer is 1 1/2" (37.5mm).
- Bonnets must not be moved forward or overlapped.

- Front bonnet bolts may go through either the slam panel, inner wings or the chassis or you may weld / bolt a piece of 2" x 2" (50mm x 50mm) metal SHS OR 3" x 3" (75mm x 75mm) metal angle to a maximum length of 3" (75mm) for the bonnet bolt to pass through and the be no higher than the top of the chassis.
- Crush tubes may be used under the bonnet only and not in the boot area, which must be a maximum of 2" (50mm) outside diameter steel tube, with a maximum 5mm wall thickness. If bolted, a secondary plate on the opposite side is not permitted. Front crush tubes must not be bolted or on sliders and they must fall out when the bonnet bolts are removed. The front crush tubes must either sit on top of the wing or on top of the chassis and not through them,
- Rear crush tubes can be secured by either bolting or welding.
- Maximum size of bolt or studing is 1" (25mm), including shouldering. Cam wheels must not be used as bonnet washers. Maximum size of the washer is 7" (175mm) x 5" (125mm).
- Maximum length of chain if used is 24" (60cm).
- Boot lid or rear door on estate cars may be bolted. If using bolts, a maximum of four, one in each corner, a maximum size of 3/8" (9mm) maybe used, or if using chain up to 24" (60cm) in length is permitted.
- If you can not get to one side and have to weld a plate, this plate must be no bigger than 6" X 3" and can only be welded to either the boot or the rear quarter panel.

### Roof Plate

A flat steel plate (3mm minimum) covering the sunroof (or where a manufactured sunroof would typically be) must be fitted. It must be secured with a minimum of 8 m8 bolts and if bolted through the roll cage can not be any further back than 75mm from the cage uprights. ~~It must not fold down the side of the roof and bolt through pillars.~~ **The roof plate should be bolted to the roof structure, not just to the roof skin, on modern bonded construction**

### Wings

- Front wings may be folded and two additional bolts may be added to secure the wing.
- A maximum of two additional bolts are allowed on rear wings/wheel arches.
- Cars manufactured without metal inner wings MUST not be fitted with fabricated panels.
- Cars with inner wings cannot be replaced with thicker or additional material.

### General

- If the complete dashboard has been removed, then you may be required to make an additional brace to secure the steering column, however this is mandatory if the standard support is removed i.e. cross bar on a Mondeo.
- No screen bars allowed.
- You are not permitted to strengthen the gearbox tunnel.
- Expanding foam or any other material must not be used to fill chassis or door sills etc.
- Any repair welding can only be made with the same gauge metal as the original part of the body or chassis being repaired (maximum of 3" strip This can only be secured by tack welding - welding 1" (25mm) with a 1" (25mm) gap before the next weld. One plate can be used to secure the inner wing to the chassis rail. – THIS IS ONLY ON NEW CAR BUILDS.
- It is not permitted to panel in headlight and window apertures.
- It is not permitted to panel in the inside of doors and or the rear parcel shelf and these must be left as original. Drivers name visors must be at the top of the windscreen only and must not be welded in place. THIS INCLUDES CHAMPIONSHIP MEETINGS.
- Visor plates must have a straight, horizontal base line and be no more than 200mm deep in the centre, and must not impede exit.
- Pulling eyes may be fitted to the front and rear of vehicles to help straighten them and not strengthen them. A maximum of six per vehicle can be used and must be 150mm square maximum size of square plate only, **and may only be fitted in front of the front axle and behind the rear axles, with one bolt only to secure them.**

### Suspension

- You may strengthen the Track Control Arm (the steering adjustment arm on the steering rack) by welding or sleeving.



- You may strengthen the standard original top and bottom arm, but this must remain standard in dimension.
- Re-positioning of the ball joint is not allowed.
- Suspension legs may be welded **or clamped** to the hub.
- Front and rear sub frames may be secured by bolting or tack welding to the width of the mounting only.

## • **FUEL SYSTEM**

- The original petrol tank must be removed and replaced with a maximum size 2-3 gallon safety tank fitted inside the car on or under the roll bar. Before fitting, the tank should be carefully checked to see that it cannot leak when inverted or on its side and the outlet must be from the top of the tank. The vent pipe from the top of the tank must be terminated below the floor level of the car.
- All fuel lines must be in good condition and securely clamped.
- With carburettor fuelled cars, a manual shut-off tap must be fitted within reach of the driver when strapped in the car, but with fuel injected cars, the fuel flow must be controlled by the battery isolator switch. Immersed fuel pumps are permitted.
- All fuel tanks must be of steel construction and have a metal screw top and must be fitted ONTO the H frame and NOT on the H Frame Floor plates, i.e. NOT on the car floor itself.
- A one-way valve must be fitted to the breather pipe.

## • **ELECTRICAL SYSTEM**

- Batteries must be bolted or clamped in position and completely covered with rot-proof material to prevent acid leakage. Ratchet straps may be used as a secondary fixing only. Batteries must be fitted on or under the roll bar. If batteries are secured in a box the maximum dimensions are 18" x 12", 460mm x 300mm.
- Alternators, if fitted, cannot be wired to charge.
- All wiring must be fully insulated.
- Electrical starters must be fitted and in working order.
- Ignition and starting must be activated through an insulated switch, not by connecting bare wires together. A battery cut off switch MUST be mounted on the roll cage on the near side of the car; the switch must be wired to the earth side of the battery.
- Switches/cutoffs/ecus if tunnel mounted can be mounted on a plate no bigger than 300x150mm (12"x6") and fitted behind the gear lever with two bolts maximum.
- Engines that are fitted with ignition system relying on a flywheel sensor (or similar), must not be modified to use a gear driven distributor.
- Ignition boxes on any fuel injection engine converted to carburettor are free, aftermarket products mapped to suit or modified original boxes modified are allowed

## • **COOLING SYSTEM**

- Only rectangular or L shaped tanks are permitted, with no braces. An L-shaped tank may extend towards the turret on Passenger side of the engine only.
- An L-shaped tank may extend towards the turret on one side of the engine only.
- Flat type water tanks laid on top of the engine are NOT allowed.
- Any modifications must be within the original bonnet outline.
- U Shaped tanks are NOT allowed.
- Water tanks must not be bolted to the drivers' side strut top/shock absorber mount.
- **All parts of the water tank must be 30mm above the top of the chassis rails and no part of the water tank can touch or be linked to the engine cradle/mounts in any way at all. Tanks, fixings, brackets and washers** must not extend beyond the front of the engine block.
- The front of the engine is classed as the block not the pulleys or water pumps etc.
- These tanks must only be secured by four fixings and may not be welded into the car or connected to any door or floor plates in any way. The tank must NOT be bolted to or through any part of the chassis. Bonnet bolts may go through the water tank but if you choose this option they must not be connected to the chassis in any way & only through the inner wing.
- Only two outlets are allowed from the water tank.
- **PLEASE NOTE THAT WATER TANKS ARE FOR COOLING PURPOSES ONLY AND NOT FOR STRENGTHENING, AND ALL PARTS MUST CARRY WATER.**
- The water pump may be removed and blanked off.

- Electric water pumps are allowed.
- No cutting of bulkheads allowed.
- Tanks must be non-pressurised.
- An overflow pipe, minimum size ½" (13mm), must go under the floor of the car and terminate at the back axle.
- Water outlets may be modified but not used for armouring, **and cooling pipes that pass in front of the engine must be flexible and not metal.**

## • **ENGINES, GEARBOX & PROPSHAFTS**

- You may replace the standard engine with any engine, provided it is of the same or smaller cc.
- On transplanted engines the position of the mounts on the engine are free, but the rule on chassis or cross member mounts is as above. The purpose is to hold the engine and not strengthen the car.–All parts must be behind the front face of the engine block. Engine cradles/mountings must be made of material no thicker than 10mm. Plate or angle along the chassis and be no longer than 250mm, bolted through the chassis with a maximum of 2 bolts per side, with washers of 100mm square maximum. Mounts on the engine must not be any further back than the front face of the bellhousing, no higher than the top of the block, and no further forward than the front face of the block. Cradles/mounts may be bolted through the subframe or the chassis but not both. Aluminium engine cross members may be replaced with a copy made from steel. **The maximum measurement of an engine cradle/mounts from front to rear is 250mm, this is measured from the furthest point back to the furthest point forward, excluding the plates on the engine block. THIS RULE COMES INTO FORCE MARCH 12st 2024.**
- The external parts of the engine must remain standard.
- Additional gearbox mounts are only allowed on rear wheel drive cars.
- Flywheels may be modified.
- Prop shafts may be made and modified to use sliding components.
- Drive shafts may be modified using sliding components.
- No turbos or superchargers.
- No dry sump systems.
- Bulkheads must remain original and not be cut or modified to fit an engine. You may cut a hole in the bulkhead to accommodate the wiring and fuel pipe.
- Any Ford Pinto, Duratec 'i4' or Zetec engine and gearbox may be used in any RWD car as long as this is no larger than the original engine cc.
- Gearbox mountings on rear wheel drive cars must be original, and can be modified to be solid, or may have secondary fixing of a ratchet strap No additional metal is allowed on the chassis to mount the gearbox, but it is permitted to bolt a plate size 150mm x 250mm x 6mm maximum to the top of the transmission tunnel to facilitate the use of a ratchet strap.

### **8a. ENGINE / CAM GUARD**

- This can only be bolted to the engine. It cannot be butted or connected or bolted to any of the engine mounting bolts or cradle bolts or water tank, and must be made of flat plate The purpose of this is to protect the front of the engine, the distributor and crank sensors. This is on RWD cars only. Anything deemed excessive will have to be removed or altered.

## • **EXHAUST & EXHAUST MANIFOLDS**

- Exhaust manifolds must remain standard to the range of engine being used.
- Tubular manifolds must be standard and genuine manufacturers items for the range of the engine being used and not an optional/aftermarket extra. In some cases these may have to be modified by heating and bending for engine transplants only, i.e. not for gain.
- If the original exhaust system has to be replaced, there must be at least one silencer to each exhaust pipe and they must be securely fixed after the manifold. **No Cherry Bombs or 'straight-through' systems allowed.**
- The original mount must be supplemented with at least one additional fixing to secure the system to the car.

- No car will be allowed to race without an exhaust system. Drivers must be aware that if your car appears to be too noisy by a scrutineer or the Steward then you may not be permitted to race or may be black flagged.

- **CARBURETTOR/INLET MANIFOLD**

- Fuel injection systems may be modified to carburettor using a manufactured or adapted inlet manifold and must run with one standard downdraft Weber type carburettor to a maximum size or equivalent 38 DGAV e.g. Pierburg, Solex, Weber. No multiple carburettor setups on four cylinder engines. Six cylinder and above engines may run twin SU carburettors but not two twin choke carburettors.
- Carburettors may be replaced with the equivalent size Weber conversion as per specification below. Adapter plates may be fitted by bolting or welding (max size carburettor allowed is 38DGAS as fitted to the 3.0 Litre V6 or 2.8 carburettor).
- Vehicles fitted with fuel injection can be used providing they are fitted using the standard banger fuel system and the fuel pump is replaced with a standard high pressure pump, or submersible pump. Suitable high pressure fuel lines must be used between the fuel pump and the injection system.
- Cold starting devices may be removed.
- Jets may be changed.
- Replacement Spindles with standard screws may be fitted, no polishing or reproofing allowed, no modifying or enlargement of any fuel galleries allowed.
- Floats must not be modified or weighted and needle valve must remain standard size, enrichment or power valve must be fitted and working.
- Solex or Pierburg carburettor may be replaced with the equivalent size Weber conversion as above.
- All carburettors must have a visual secondary fixing on the fuel inlet pipe.
- Air filters may be removed or replaced by competition type.

- **SUSPENSION, BRAKES AND AXLES**

- The use of professionally made competition quick release steering wheels is permitted and any steering columns may be used but when replacing original columns, incorporate a slider mechanism.
- Suspension components must remain standard, except where specific strengthening is allowed in section 4.
- Spring assist rubbers are allowed.
- Springs may be changed, but only one spring per corner is allowed.
- Springs may be heated or cut for lowering purposes.
- A secondary fixing is required on coil springs that may fall out, wire, chain, or both should be used.
- Shock absorbers must be standard type as fitted originally. No interchanging of suspension parts allowed.
- Bump stops may be removed.
- Camber must not be altered from standard, race damage must be proven and this will not be tolerated on new cars. The Scrutineers decision is FINAL.
- The tack welding of anti-roll bar brackets is allowed. On the Mercedes the front spring mount you may weld or bolt a support but must not be any longer than the standard spring platform.
- All suspension rubber mounted tops may be secured (no welding permitted) with a larger washer than original.
- Front suspension can only be altered with car derived parts.
- Back axles can be interchanged with car or light commercial axles but the car's ride height must remain the same.
- Front and rear axles can be changed with car derived parts but mountings must be no larger than standard. **Rear axle swops on American cars may only be with live beam axles, not independent suspension clips such as Jaguar.**
- Brakes must be effective.
- Aluminium rear hubs may be modified.

- **DIFFERENTIALS**

- Differential are free and may even be welded and locked.
- Axle casings must not be welded or reinforced.
- Replacement differential mountings may not exceed the width of the differential.

- **WHEELS**

- Any standard steel or alloy wheel that fits without modification within the body of the car may be used
- Cut and shut or banded wheels are not permitted.
- All wheel nuts must be fitted and secure.

- **TYRES**

- On unlimited meetings only, conventional road tyre up to 235 may be used and a minimum of 50 profile.
- All tyres should have a minimum durometer reading of 60, whenever tested.
- All identification markings to remain on tyres.
- Any tyre with buffed markings will not be accepted and will be subject to disciplinary action.
- Tyre gaiters are permitted.

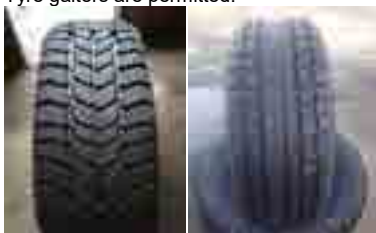

- “Run flat” tyres, 1B rated **approved** 'Track-day' tyres, Rally tyres, competition type, cut tyres, Town and Country, Mud & Snow Type or Kingpin Alpine Series tyres are NOT allowed.
- **Winter Pattern/M&S Type** Kingpin tyres eg ALP4 are banned - see example photos
- The ORCi reserves the right to ban any tyre make or type which gives an unfair advantage.
- All tyres listed in the table below are NOT allowed.

<b>AVON</b> • ACB 10 Sport • CR6ZZ (Including Sport) • Turbospeed CR28 Sport • CR500 • ZZR  <b>BRIDGESTONE</b> • Potenza S007 RFT  <b>CONTINENTAL</b> • ContiForce Contact  <b>DMACK</b> • Trackday  <b>DUNLOP</b> • Formula R D83J/D84J • Formula R D93J • Direzza 02G or 03G	• CR 311 • Sport Maxx Race • SP Sport R7  <b>FEDERAL</b> • 595 EVO • 595 RSR • FZ 201  <b>GOODYEAR</b> • EAGLE F1  <b>HANKOOK</b> • Z209 • Z210  <b>KUMHO</b> • Ecsta V700 (inc V78) • Ecsta V70A • Ecsta TW01	• Ecsta TW02 • Ecsta C03 <b>MARANGONI</b> • Zeta Linea Sport  <b>MAXSPORT</b> • RB4 Intermediate • RB5  <b>MAXXIS</b> • Maz1 Drift  <b>MICHELIN</b> • Pilot Sport Cup • Pilot Sport Cup 2 • TB 15 • TB 15 (f & r)  <b>NANGKANG</b> • NS-2R	<b>PIRELLI</b> • P Zero Trofeo • P Zero C • CA67 • CF67 • P Zero Corsa • P7 Corsa Classic • P Zero Torfeo R12  <b>SILVERSTONE</b> • FTZ Sport RR • FTZ Wet Tyre • S575 • S585 <b>SYRON</b> <b>TOYO</b> • R888 • R1-R AO42R <b>Zestino</b>
---	---	--	--

- **SAFETY EQUIPMENT** Please check the website ORCi .co.uk for current Safety Equipment regulations

- **SEATS**

- The driver's seat must be secured and supported to the roll cage at shoulder level by bolting or tying.
- The 2<sup>nd</sup> roll cage cross brace may be used to support the seat, but it must be set below the bottom of the window aperture or you may construct and weld a frame on to the cage to support the seat.
- The driver's seat must be a standard production seat, **with airbags deactivated or removed**, not a racing seat.

- **NUMBERS**

- You must fit a fin plate to the roof of your car, minimum size 18" x 12"(460mm x 300mm) and a maximum size of 20" x 15" (510mm x 380mm).
- **Roof Fin plates must be mounted to the roof skin and must not overhang the tailgate or any part of the rear of the car.**
- Your number must be either white on a black background or black on a white background, no other colours allowed, **any other writing allowed must not interfere with the numbers**, which must be minimum size 9" (230mm) high x 1½" (40mm) wide. If your number is not to the above specification, you may not be lap scored.

- **ROOF GRADES**

- If applicable to the Promotion you race for, your grade colour must be painted on the whole roof of your car.

- **FINAL PREPARATION**

- Rusty or dirty vehicles will not be allowed out onto the circuit.
- Rude or provocative slogans are not allowed; please remember this is a family sport.
- In addition to the car construction rules, all cars presented at scrutineering must be considered safe and not unsightly.
- New under sealing of the underside of the car is strictly forbidden.



# **2024 NATIONAL BANGER SPECIFICATIONS** **FOR OTHER CLASSES**

**REVISED RULES FOR 2024 IN BOLD/ITALIC/RED PRINT**

**ITEMS MARKED ~~STRIKETHROUGH~~ ARE NO LONGER ALLOWED**

**2023 National Banger Technical Specifications Excluding Unlimited cc**

**These rules are valid with January 1<sup>st</sup> 2024**

**The overriding principle of these regulations is that unless it is stated that you can do it, you must work on the principle that you CANNOT.**

## **• TYPE OF CAR PERMITTED FOR USE**

- You must use any four wheel saloon, coupe, estate car or people carrier. No SUV's or 4 x 4 vehicles allowed.

Furthermore, classifications may be done using engine cc and may include (but not exclusively) the following:

### **2 Litre National Bangers**

- On rear wheel drive cars the engine and gearbox can be replaced with any other 2 litre engine.  
Any 2 litre Front Wheel Drive shell may be used, including the Jaguar X type. The Ford Mondeo Mk 3 may be fitted with a front subframe from a Mk 1 or Mk2 Mondeo in standard form, with original suspension and must be fitted using the original front mounting points, and the subframe extended at the rear with two pieces of 50x25mm(2"x1") box section to mate with the rear mounting points
- Engine swaps in 2 litre class are permitted as following. The Ford Zetec (2.0 or under) or Vauxhall engine (2.0 or under) and gearbox may be fitted to any under 2.0 front wheel drive car, but suspension and subframe must remain standard to the vehicle being raced. Drive shafts are allowed to be cut and shut together, and should be done so to a safe standard, sliding shafts are not permitted. Engine and gearbox mounts may be fabricated to fit engine swaps but must each be no longer front to back than 8 inches in total, and must use original mount locations on chassis with one extra fixing. The rear mount must remain no bigger than original size. No car smaller than Astra Mk5 is permitted.
- Bonnet plates (Corner Plates) must be a maximum of 400mm x 400mm (measured along the wing / across the scuttle panel) – This size is for 2 Litre National Bangers ONLY

### **Micro (under 1300cc) National Bangers**

- The Vauxhall Corsa C must have a maximum engine size of 1200cc (1400 engines are not permitted)  
Nissan Micra K12 and Vauxhall Corsa D are NOT permitted in Micro banger events.
- Maximum engine size is 1300cc on all other models.
- No engine swaps are permitted. It is permitted to change fly by wire throttles with earlier cable operated throttles from the same make and model, but larger throttle bodies may not be used.
- Engine mounts. Original mounts can be strengthened but must remain in original position OR replaced with fabricated mounts, fabricated mounts can be bolted to the chassis with the maximum of 3 bolts, the maximum size of mount on the chassis is 8 1/2 inches and must not

pass the engine face more than 50mm for a bolt. Original bolt holes can be used but new holes can be made. The mounts can include a sump guard (if the sump is exposed) an oil filter guard (if the filter is forward facing) and a knock sensor guard (if sensor is forward facing) this mount can only be bolted to the front of the engine or engine mount, NOT UNDER the engine or to any gearbox fixings, the guard can be a max of 6mm and is solely to keep the engine running. Engines CANNOT be attached to subframes on Astra/Corsa  
 Gearbox mounts can be strengthened OR replaced with fabricated mounts, the maximum size of mount on the chassis is 6 inches, and cannot pass the engine face. Original fixing holes can be used, or new holes drilled. ( for clarity the engine face is where the manifold bolts to engine). An exception to this rule is the Fiesta/KA, where the gear box mounting must not go above the main chassis leg and be bolted only to the lower bolts in the chassis of the gearbox mount. No part of the mounting can protrude further forward than 10mm of the gearbox.

- No additional metal is allowed on the chassis to mount the engine, and engine mounts must not protect water outlets or distributors etc.
- Only cars which are included on the following list can be used. For any cars which are not included please contact the relevant promoter for permission to use the car you believe meets the necessary specifications.

<b>LIST OF ELIGIBLE CARS FOR NATIONAL MICRO BANGERS</b> <b>From 1/1/2023</b>	
<ul style="list-style-type: none"> <li>• Austin - A30 / A35 / A40 (Farina only NOT Somerset or Cambridge) / Metro 1000, 1300 / Allegro 1000, 1100, 1300 / Mini (classic only)</li> <li>• Chevrolet - Matiz / Spark (Mk2 + 3)</li> <li>• Citroen – 2CV / Diane / AX / Saxo / Visa / C1 / C2 (1.1 only)</li> <li>• Daewoo – Matiz</li> <li>• Diahatsu – Charade MK 1, 2, 3</li> <li>• Datsun – 100A (Cherry)</li> <li>• Fiat – Panda (Mk1 &amp; 2 only) / Punto (Mk1, 2) / Uno / 126 / 127 Cinquecento / 500 only (NOT 500C, 500L or 500X)</li> <li>• Ford – Fiesta (Mk 1, 2, 3 , 4 , 5, 6) / KA (1996-2016) / Popular 100E / Anglia</li> <li>• Hillman – Imp (derivatives of this model)</li> <li>• Honda - Civic (1st generation 1972 – 1979 only)</li> <li>• Hyundai – Amica / Atos / i10 / Getz (1.1 only)</li> <li>• Kia – Pride (1.1 only) / Picanto</li> </ul>	<ul style="list-style-type: none"> <li>• Lada – Samara</li> <li>• Lancia – Fulvia</li> <li>• Mitsubishi Colt (Mk 1, 2, 3 only)</li> <li>• Mazda – 121</li> <li>• Morris – 1100 / 1300 / Minor</li> <li>• Nissan – Micra (K10, K11) / Pixo</li> <li>• Peugeot – 104 / 106 / 107 / 108 / 205 / 206 (Mk1 Hatchback only)</li> <li>• Proton – Satria / Compact</li> <li>• Renault – 4 / 5 / 6 / 10 / Clio (Mk1, 2 only) / Modus (Mk1)</li> <li>• Riley – Elf</li> <li>• Rover – Metro (known as 100)</li> <li>• Seat – Mii</li> <li>• Skoda – Citigo / Favorit (Hatchback only)</li> <li>• Smart Car</li> <li>• Subaru – Vivio</li> <li>• Suzuki – Alto / Celerio / Swift (to 2003) / Wagon R / Wagon R+</li> <li>• Talbot – Samba /</li> <li>• Toyota – Starlet / Aygo</li> <li>• Vauxhall – Corsa (B + C only) / Chevette / HA Viva / Nova / Viva (2014 on)</li> <li>• Volkswagen – Beetle (type 1) / Fox / Lupo (1.0L only) / Polo (Mk 1, 2) / Polo (Mk3 Hatchback only) / Up</li> <li>• Wolseley – Hornet</li> <li>Yugo</li> </ul>

### Van National Banger Events

- Roll cages must be a minimum of one across bar up to a maximum of a full roll cage. If the single bar option is used, it must be fitted centrally behind the driver's seat, plated top and bottom, minimum four bolts per plate. A full roll cage is recommended on fibreglass bodies and flat fronted vans, so as to help protect the driver's feet. If fibreglass type body, then the door plate can be welded to the roll cage on the driver's side. The driver's seat must be secured at shoulder height to the door pillars or cage, if fitted. If for example an LDV high top

fibreglass roof van is used than you may use two bars going up with cross bars, with two bars going back at 45 degrees. Each promotion may have additional regulations – please check.

- An engine guard is permitted. The scrutineer's decision is final.
- Vans with independent chassis, the rear end must be removed back up to the rear spring hanger, to allow the body to collapse.
- If it is not possible to fit a water tank within the National Banger rules above, the local Promoter may allow the fitment elsewhere within the vehicle.
- Engines must be in original position.
- No air cooled 'Plant' type engines
- Roll cage must not extend beyond the front bulkhead.

### **1600cc National Bangers**

- Maximum engine size is 1600cc.
- No engine swaps are permitted. It is permitted to change fly by wire throttles with earlier cable operated throttles from the same make and model, but larger throttle bodies may not be used.
- Engine mounts. Original mounts can be strengthened but must remain in original position OR replaced with fabricated mounts, fabricated mounts can be bolted to the chassis with the maximum of 3 bolts, the maximum size of mount on the chassis is 8 1/2 inches and must not pass the engine face more than 50mm for a bolt. Original bolt holes can be used but new holes can be made. The mounts can include a sump guard (if the sump is exposed) an oil filter guard (if the filter is forward facing) and a knock sensor guard (if sensor is forward facing) this mount can only be bolted to the front of the engine or engine mount, NOT UNDER the engine or to any gearbox fixings, the guard can be a max of 6mm and is solely to keep the engine running. Engines CANNOT be attached to subframes unless it is original fitment. Gearbox mounts can be strengthened OR replaced with fabricated mounts, the maximum size of mount on the chassis is 6 inches, and cannot pass the engine face. Original fixing holes can be used, or new holes drilled. ( for clarity the engine face is where the manifold bolts to engine) No part of the mounting can protrude further forward than 10mm of the gearbox.
- No additional metal is allowed on the chassis to mount the engine, and engine mounts must not protect water outlets or distributors etc.
- Bonnet plates (Corner Plates) must be a maximum of 400mm x 400mm (measured along the wing / across the scuttle panel)
- All cars with aluminium bumpers must have the bumper and retaining irons removed.

### **Special Meetings**

- Your promoter will state either via the fixture list or special entry form at which meetings this rule can be used and therefore cannot be used by a driver regardless of type of car at a normal meeting!!
- Promoters may run special meetings for a certain type of vehicle e.g. 7.5 tonnes vehicles, SUV's, 4 X 4's, Reliant Robins, Coaches etc, for which rules will be issued by the Staging Promoter. Left hand drive vehicles may be permitted at the promoter's discretion – this should be checked in advance with the staging promoter.

#### **• STRIPPING & PREPARATION**

- It is compulsory to remove all the interior, glass, airbags and charges, spoilers and side-skirts.
- The complete dashboard should be removed wherever possible.
- Remove all seats except the driver's which must be retained, the use of a racing seat is not allowed.
- Remove spare wheel carriers and tow bars plus *associated steelwork* if fitted.
- Original fuel tanks must be removed. If however, the tank is an integral part of the body you must remove as much as possible.
- You may use the original standard steel bumper (with the exception of Vectras and Mondeos noted below). If a front bumper is fitted, a maximum of three additional bolts may also be



fitted to secure it in place. No wrap around bumpers allowed. Plastic bumpers must be removed. All cars with aluminium bumpers must have the bumper and retaining irons removed before racing e.g. Volvo 2 series and Saab. You may fit a bumper/flat plate 100mm x 3mm in its place. This may be folded back a maximum of 3" (75mm) with a maximum of two bolts per side. The bolts must go THROUGH the chassis and not UP the chassis. Vectra's, Mk1 or Mk2 Mondeo's must not be fitted with bumpers or steel plate.

- Later type cars with extended chassis rails e.g. Mk3 Mondeo/Focus, may also be fitted with a bumper or plate to the above rule or cut the chassis rail back to the front valance.
- Chassis rails CANNOT be cut/shortened on fresh cars, if the chassis is cut back due to rot or damage the front crossmember CANNOT be re-fitted, the 3mm X 100mm Bumper MUST then be fitted.

- **ROLL BAR**

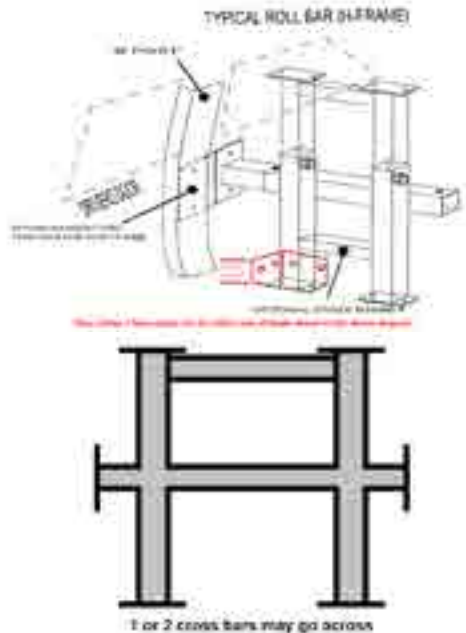

These two diagrams are a guideline to how the frame should be constructed but gusseting or triangulation is accepted.

- You must fit a single "hoop" roll bar in support of the door pillars, securely bolted to the roof and floor with a minimum size M12 bolt and suitable washers. Recommended that rollcage uprights to be above head height before adjustment. It is compulsory to have two bolts in the uprights.

- On adjustable roll cages the bolt(s) governing the height of the roll bar must pass through the roll bar socket and the extension, and spacer between the roof and roll bar may not exceed 50mm (2").
- You must have a minimum of four bolts in the top and four in the bottom, with a maximum of eight in the bottom on each side. The maximum size of the base plate is 15" (385mm) x 11" (280mm). The plate may go up the side of the sill or straight up the rear panel up to a maximum of 4" (102mm) high. This must be the same length and width as the base plate/floor plate of the cage. A maximum of two bolts are permitted through the side.
- Roll cages may be adjustable (height and width), however the use of screw adjusters i.e. acrow style, are not permitted.
- The roll cage must be fitted upright or dog-legged, but not leaning back or forward.
- It is compulsory to pad with foam - roll cages by the driver's head, B pillar and steering column, and advisable to pad the inside of the driver's door
- The hoop must be one piece, or two uprights and one top bar of a welded construction. This top bar should be as shown at the top of the uprights.
- A second cross bar is compulsory, a third is optional; these must be welded or bolted to the uprights.
- **THE ROLL BAR MUST NOT HAVE ANY REAR SUPPORTS but may have extensions no further forward than the B post (see diagram) (this applies to both sides of the car). If used, it is highly recommended that this is bolted through the B post.**
- You may bolt the roll bar through both sides of the car.
- The minimum size steel for the roll bar is 2" (50mm) x 2" (50mm) RHS or tube equivalent, up to a maximum size of 4" (100mm) x 4" (100mm) RHS or tube equivalent. A minimum wall thickness of 3mm is required.
- Crossbars must have a 5" (125mm) square end plate fitted. This must be a minimum of 6mm thick.
- You must tie the seat at shoulder level to the roll cage or B pillar. This must be done through the seat frame and not the headrest; you may fit the 2<sup>nd</sup> cross bar in support of the seat just below the window aperture or weld a frame on the cage to support the seat at the top.

#### • **STRENGTHENING & PREPARATION**

- **Cars that fail pre or post-race scrutineering, found to be armoured or strengthened, including engine or gearbox suspension mounts that are over the top and not rectifiable on the day, will receive an immediate ORCi ban. If the vehicle can be rectified at the track then the vehicle must race, otherwise the driver will be subject to an ORCi ban.**

#### **Doors & Door Plates**

- The driver's door may be welded, but must have no additional strengthening (this includes gussets) other than steel RHS, which is allowed in the lower window aperture of the drivers and rear driver's door, not extending further than the rear of the H frame. **Please note that this is not allowed on the passenger side.**
- A FLAT (no channel or angle) steel plate MUST be bolted over the driver's door to the following dimensions:
- **Height – minimum 10" (255mm) to a maximum of 15" (380mm)**
- **Thickness - minimum 3/8" (9mm) – 3/4" (20mm)**
- This must be fitted with a minimum of 3" (75mm) and a maximum of 6" (150mm) past the A & B pillars.
- This must be securely bolted with a minimum of four bolts.
- It is not permitted to cut slots in the driver's doorplate. Holes for bolts only.
- There must be at least one bolt through the A pillar and one through the B pillar or through the roll cage.
- The bolt size must be at least M16 studding or bolt. M12 is acceptable on all other bolts
- For 2 door and pillar-less cars (no B Pillar), the door plate MUST be bolted through the roll cage.
- Door plates must extend past the rear roll cage upright
- Door plates cannot be joined to the water tank in any way.
- All other doors must be secured by bolting, chains or seat belt webbing. The maximum number of bolts permitted is four per door. Where plates are used to secure doors (other than

the driver's door), the plates must be a maximum of 12" x 12" (300mm x 300mm) – you may use ONE additional bolt per plate to secure through the A or B Pillar, this must be a minimum size ¼" (6mm).

### **Driver's Floor Plate**

- A steel plate fitted to the drivers floor pan is compulsory Floor plates may extend no further back than the front of the seat squab and must remain in the drivers footwell only and must be made of 3mm steel minimum
- It must be no thicker than 6mm and must be bolted in only.
- Floor plates may extend up the side of the transmission tunnel, to the same height as the door sill, and up the bulkhead to within 200mm (8") of the top of the bulkhead, but the plate can only be bolted through the floor and the A-pillar only, not to the sill or bulkhead. You may put two bolts maximum in the gearbox tunnel with a maximum 50mm washer size.
- A 4" (100mm) steel plate no thicker than 6mm bolted through the A pillar to the door plate can be welded or bolted to the floor plate.

### **Bonnet/Boot**

- The driver must present their car for pre-meeting safety checks with the bonnet and bolts but they must NOT be fixed to the car.
- Triangular corner plates or straps may be used to secure the rear of the bonnet. Maximum size 300mm x 300mm (measured along the wing / across the scuttle panel) – National Micro Bangers and under 2 litre Banger events
- They must be attached to the car by bolting or tack welding to a maximum of 1" (25mm) weld with a 1" (25mm) gap in between. Plates or straps must be placed no further than 12" (300mm) across or down from the back edge and side of the bonnet. WELDING MUST NOT REACH THE 'A' PILLAR ON THE PASSENGER SIDE. All corner plates may be a maximum of 4mm thick.
- Bonnets must be bolted down using a maximum of four bolts, two bolts in either side of the bonnet. Maximum height of bolt above the washer is 1½" (37.5mm).
- Bonnets must not be moved forward or overlapped.
- Front bonnet bolts may go through either the slam panel, inner wings or the chassis or you may weld / bolt a piece of 2" x 2" (50mm x 50mm) metal SHS OR 3" x 3" (75mm x 75mm) metal angle to a maximum length of 3" (75mm) for the bonnet bolt to pass through.
- Crush tubes may be used, which must be a maximum of 2" (50mm) outside diameter steel tube, with a maximum 5mm wall thickness. If bolted, a secondary plate on the opposite side is not permitted.
- Rear crush tubes can be secured by either bolting or welding.
- Maximum size of bolt or studding is 1" (25mm), including shouldering. Cam wheels must not be used as bonnet washers. Maximum size of the washer is 7" (175mm) x 5" (125mm).
- Maximum length of chain if used is 24" (60cm).
- Boot lid or rear door on estate cars may be chained or bolted. If using bolts, a maximum of four, one in each corner, a maximum size of 3/8" (9mm) maybe used, or if using chain up to 24" (60cm) in length is permitted.

### **Wings**

- Front wings may be folded and two additional bolts may be added to secure the wing, however this is not allowed on Vectra's or Mk1 or Mk2 Mondeo's.
- A maximum of two additional bolts are allowed on rear wings/wheel arches.

### **General**

- If the complete dashboard has been removed, then you may be required to make an additional brace to secure the steering column, however this is mandatory if the standard support is removed i.e. cross bar on a Mondeo.
- No screen bars allowed.
- You are not permitted to strengthen the gearbox tunnel.
- Expanding foam or any other material must not be used to fill chassis or door sills etc.

- Roof plates are compulsory. The minimum thickness of flat steel plate is 3mm, and it must be secured by a minimum of 8 bolts or welded. The roof plate must not extend further back than 75mm from the rear of the roll cage uprights.
- Any repair welding can only be made with the same gauge metal as the original part of the body or chassis being repaired (maximum of 3" (75mm) square). This can only be secured by tack welding -welding 1" (25mm) with a 1" (25mm) gap before the next weld. One plate can be used to secure the inner wing to the chassis rail. – THIS IS ONLY ON NEW CAR BUILDS.
- It is not permitted to panel in headlight and window apertures.
- It is not permitted to panel in the inside of doors and or the rear parcel shelf and these must be left as original. Drivers name visors must be at the top of the windscreen only and must not be welded in place. .  
THIS INCLUDES CHAMPIONSHIP MEETINGS.
- Visor plates must have a straight, horizontal base line and be no more than 150mm deep in the centre and must not impede exit.

### **Suspension**

- You may strengthen the Track Control Arm (the steering adjustment arm on the steering rack) by welding or sleeving.
- You may strengthen the standard original bottom arm, but this must remain standard in dimension.
- Re-positioning of the ball joint is not allowed.
- Suspension legs may be welded to the hub.
- No additional strengthening of any other suspension parts is allowed.
- Sub frames must not be welded in place.

### **Guards/Covers**

- Where relevant, a crank sensor protector may be fitted to a maximum size of 2" x 2" (50mm x 50mm) steel angle, 4" in length (100mm), with a maximum of two bolt fixings, secured to the bell housing/engine.
- You may fit a steel plate distributor guard to the following specification.
  - Maximum area of 9" x 9" (230mm x 230mm), with a maximum thickness of ¼" (6mm).
  - The steel plate may be bolted or braced using steel RHS, maximum 1" x 1" (25mm x 25mm) or welded TO THE ENGINE ONLY, I.E you CANNOT fit the guard to the sub-frame or gearbox and it must not be touching the water tank in any way.
- Forward facing cam belt engines may run a cam cover, but these must be the same silhouette as the original and bolted to the original mountings. For avoidance of doubt, cam guards cannot be used where the engine does not have a cam belt. Maximum thickness of cam guard is 6mm.
- On Micro Bangers only, a sump guard may be bolted or welded to the front of the engine/engine mount on the driver's side only, and only drop down in front of the sump and no lower than the bottom of the sump. The guard must have a maximum thickness of 6mm plate; no steel RHS, SHS or angle is permitted. The scrutineer's decision is final on oversizing.
- On Micro Bangers & up to 1600cc Bangers, an oil filter guard is permitted on forward facing oil filters. It must be made from flat plate being a maximum of 4" x 4" diameter and a maximum of 6mm thick, secured back to the engine using 2 pieces of 1" box section. The plate must not come forward of oil filter more than 1" and be mounted on the engine as close as possible to oil filter. The object of this is to prevent oil fires and not to strengthen the car therefore if the scrutineers believes the guard to be excessive you will be asked to remove it.
- A clutch guard is permitted on front of the engine/gearbox if fitted forward facing of the engine, with a maximum size as follows:- 6" x 4" and a maximum thickness of 6mm. This must be secured to the engine/gearbox only.

### • **FUEL SYSTEM**

- The original petrol tank must be removed and replaced with a maximum size 2-3 gallon safety tank fitted inside the car on or under the roll bar. Before fitting, the tank should be carefully checked to see that it cannot leak when inverted or on its side and the outlet must be from the top of the tank. The vent pipe from the top of the tank must be terminated below the floor level of the car.
- All fuel lines must be in good condition and securely clamped.

- With carburettor fuelled cars, a manual shut-off tap must be fitted within reach of the driver when strapped in the car, but with fuel injected cars, the fuel flow must be controlled by the pump cut off switch. Immersed fuel pumps are permitted.
- All fuel tanks must be of steel construction and have a metal screw top and must be fitted ONTO the H-frame and NOT on the H Frame Floor plates, i.e. NOT on the car floor itself.
- A one-way valve must be fitted to the breather pipe.

- **ELECTRICAL SYSTEM**

- Batteries must be bolted or clamped in position and completely covered with rot-proof material to prevent acid leakage. Ratchet straps may be used as a secondary fixing only. Batteries must be fitted on or under the roll bar. If batteries are secured in a box the maximum dimensions are 18" x 12", 460mm x 300mm.
- Alternators, if fitted, cannot be wired to charge.
- All wiring must be fully insulated.
- Electrical starters must be fitted and in working order.
- Ignition and starting must be activated through an insulated switch, not by connecting bare wires together. A battery cut off switch MUST be mounted on the roll cage on the near side of the car; the switch must be wired to the earth side of the battery.
- Engines that are fitted with ignition system relying on a flywheel sensor (or similar), must not be modified to use a gear driven distributor.
- Ignition boxes on any fuel injection engine converted to carburettor are free, aftermarket products mapped to suit or modified original boxes modified are allowed.
- On fuel injection cars the engine management system including ignition boxes must remain as originally fitted and not re mapped.

- **COOLING SYSTEM**

- Water tanks on fwd cars may not protrude further forward than the front face of the cylinder head which is defined as the face of the head to which the manifold is bolted'
- Only rectangular or L shaped tanks are permitted, with no braces. An L-shaped tank may extend towards the turret on Passenger side of the engine only
- Water tanks must not be bolted to the drivers' side strut top/shock absorber mount..
- Any modifications must be within the original bonnet outline.
- U Shaped tanks are NOT allowed.
- Tanks must not extend beyond the front of the engine block.
- The front of the engine is classed as the block not the pulleys or water pumps etc.
- These tanks must only be secured by four fixings and may not be welded into the car or connected to any door or floor plates in any way. The tank must NOT be bolted to or through any part of the chassis, bonnet bolts may go through the water tank but if you choose this option they must not be connected to the chassis in any way & only through the inner wing.
- Only two outlets are allowed from the water tank.
- **PLEASE NOTE THAT WATER TANKS ARE FOR COOLING PURPOSES ONLY AND NOT FOR STRENGTHENING, AND ALL PARTS MUST CARRY WATER.**
- The water pump may be removed and blanked off.
- Electric water pumps are allowed.
- No cutting of bulkheads allowed.
- Tanks must be non-pressurised.
- An overflow pipe, minimum size ½" (13mm), must go under the floor of the car and terminate at the back axle.
- Water outlets may be modified but not used for armouring.

- **8. ENGINES, GEARBOX & PROPSHAFTS**

- On Micro Banger meetings, gearboxes may be changed within the manufacturers range.
- The external parts of the engine must remain standard.
- No skimming of the head more than 60 thou from standard.
- No porting or gas flowing.
- No removing or adding material to the ports or combustion chamber.
- No ST170 or ST220 engine components are permitted.

- The cylinder head and the camshaft(s) must remain standard and the Ford Zetec engine must stay on the original Ford camshafts. You may skim the head face for head gasket purposes only.
  - On front wheel drive gear box mounts can be modified but must occupy the original position.
  - Flywheels may be modified.
  - Clutches are free.
  - Prop shafts may be made and modified to use sliding components.
  - Drive shafts must be standard to the car and must not be fabricated.
  - No turbos or superchargers
  - No dry sump systems.
  - Bulkheads must remain original and not be cut or modified to fit an engine. You may cut a hole in the bulkhead to accommodate the wiring and fuel pipe.
  - Any Ford Pinto, Duratec or Zetec engine and gearbox may be used in any RWD car as long as this is no larger than the original engine cc.
  - Engine mounts may be strengthened but must remain in the original place if fitted. No additional mounts allowed. Modified engine mounts can be welded to the cross member, but must be bolted if attached to the chassis.
  - The top left engine mounting on a Mondeo/Focus may have an extra engine mount fitted on the rear of the engine.
  - Gearbox mountings on rear wheel drive cars must be original, and can be modified to be solid, or may have secondary fixing of a ratchet strap, or M16 studding made into a u-bolt with a flat plate as a washer maximum size 50mm wide 6mm thick, and 300mm long. No additional metal is allowed on the chassis to mount the engine, and engine mounts must not protect water outlets or distributors etc.
  - External cambelt engines may have a copy of the original cambelt cover bolted in the original bolt holes of the cover to a maximum thickness of 6mm. These cannot be bolted in any other way except through the original bolt holes.
- **9. EXHAUST & EXHAUST MANIFOLDS**
- Standard tubular manifolds may be used, only if fitted as standard to that model e.g. Nissan Primera.
  - Ford Mondeo MK1, Ford Mondeo MK2 models must use the standard cast manifold i.e. cannot use a 4 branch tubular manifold.
  - No non-standard aftermarket exhaust manifolds are permitted.
  - A Ford Mondeo MK3 running the original Mk3 engine with the inlet manifold at the front, may use the standard 4 branch exhaust manifold fitted.
  - In all cases the 4 branch manifolds allowed, must be genuine original manufacturers parts.
  - If the original exhaust system has to be replaced, there must be at least one silencer to each exhaust pipe and they must be securely fixed after the manifold. No Cherry Bombs or 'straight-through' systems allowed.
  - The original mount must be supplemented with at least one additional fixing to secure the system to the car.
  - No car will be allowed to race without an exhaust system. Drivers must be aware that if your car appears to be too noisy by a scrutineer or the Steward then you may not be permitted to race or may be black flagged.
- **10. CARBURETTOR/INLET MANIFOLD**
- Fuel injection systems may be modified to carburettor using a manufactured or adapted inlet manifold and must run with one standard downdraft Weber type carburettor to a maximum size or equivalent 38 DGAV e.g. Pierburg, Solex, Weber – NO MULTIPLE CARB SETUPS. If the engine is manufactured in both forms as standard, inlet manifold may be modified or self-manufactured items e.g. Cavalier with the earlier style inlet manifold.
  - Carburettors may be replaced with the equivalent size Weber conversion as per specification below. Adapter plates may be fitted by bolting or welding (max size carburettor allowed is 38DGAS as fitted to the 3.0 Litre V6 or 2.8 carburettor).
  - Vehicles fitted with fuel injection can be used providing they are fitted using the standard banger fuel system and the fuel pump is replaced with a standard high pressure pump, or submersible pump. Suitable high pressure fuel lines must be used between the fuel pump and the injection system.

- Cold starting devices may be removed.
- Jets may be changed.
- Replacement Spindles with standard screws may be fitted, no polishing or reproofing allowed, no modifying or enlargement of any fuel galleries allowed.
- Floats must not be modified or weighted and needle valve must remain standard size, enrichment or power valve must be fitted and working.
- Solex or Pierburg carburettor may be replaced with the equivalent size Weber conversion as above.
- All Weber carburettors must have a visual secondary fixing on the fuel inlet pipe.
- Air filters may be removed or replaced by competition type.
- 

### • **11. SUSPENSION, BRAKES AND AXLES**

- The use of professionally made competition quick release steering wheels is permitted and any steering columns may be used but when replacing original columns, incorporate a slider mechanism.
- Suspension components must remain standard, except where specific strengthening is allowed in section 4.
- Spring assistor rubbers are allowed.
- Springs may be changed but no 2¼ type competition springs.
- Springs may be heated or cut for lowering purposes.
- A secondary fixing is required on coil springs that may fall out; chain or wire should be used.
- Shock absorbers must be standard type as fitted originally. No interchanging of suspension parts allowed.
- Bump stops may be removed.
- Camber must not be altered from standard, race damage must be proven and this will not be tolerated on new cars. The Scrutineers decision is FINAL.
- Bluebird/Micra or similar car may use a strap connecting the two wishbones, but this may not be connected to any other part of the car or the engine. This strap must be a maximum of 2"x 2" (50mm x 50mm), and can only be used on cars with no subframe.
- The tack welding of anti-roll bar brackets is allowed.
- All suspension rubber mounted tops may be secured (no welding permitted) with a larger washer than original.
- Brakes must be effective.
- Axle casings must not be welded or reinforced.

### • **12. DIFFERENTIALS**

- Ratios are free but must be standard to the range.
- Limited slip differentials (except shale see below), locked differentials, welded (except shale see below) or power-locked differentials are not allowed, even if fitted as standard or available as an optional extra to the car. However, on shale surfaces Limited Slip and welded Differentials are permitted.
- Replacement differential mountings may not exceed the width of the differential.
- 

### • **13. WHEELS**

- Any standard steel or alloy wheel up to 6½"J that fits without modification may be used.
- Cut and shut or banded wheels are not permitted.
- All wheel nuts must be fitted.

### • **14. TYRES**

- You may only use conventional road tyres up to 205/50.
- All tyres should have a minimum durometer reading of 60, whenever tested.
- All identification markings to remain on tyres.
- Any tyre with buffed markings will not be accepted, and will be subject to disciplinary action.
- Tyre gaiters are permitted.

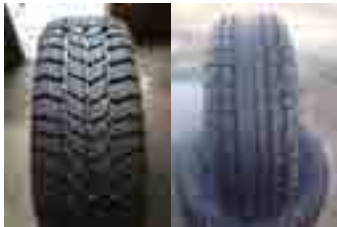

- “Run flat” tyres, 1B-rated approved ‘Track-day’ tyres, Rally tyres, competition type, cut tyres, Town and Country, Mud & Snow Type or Kingpin Alpine Series tyres are NOT allowed.
- any **Winter Pattern/M&S Type** Kingpin tyres eg ALP4 are banned - see example photos
- The ORCi reserves the right to ban any tyre make or type which gives an unfair advantage.
- All tyres listed in the table below are NOT allowed.

<p><b>AVON</b></p> <ul style="list-style-type: none"> <li>• ACB 10 Sport</li> <li>• CR6ZZ (Including Sport)</li> <li>• Turbospeed CR28 Sport</li> <li>• CR500</li> <li>• ZZR</li> </ul> <p><b>BRIDGESTONE</b></p> <ul style="list-style-type: none"> <li>• Potenza S007 RFT</li> </ul> <p><b>CONTINENTAL</b></p> <ul style="list-style-type: none"> <li>• ContiForce Contact</li> </ul> <p><b>DMACK</b></p> <ul style="list-style-type: none"> <li>• Trackday</li> </ul> <p><b>DUNLOP</b></p> <ul style="list-style-type: none"> <li>• Formula R D83J/D84J</li> <li>• Formula R D93J</li> <li>• Direzza 02G or 03G</li> </ul>	<ul style="list-style-type: none"> <li>• CR 311</li> <li>• Sport Maxx Race</li> <li>• SP Sport R7</li> </ul> <p><b>FEDERAL</b></p> <ul style="list-style-type: none"> <li>• 595 EVO</li> <li>• 595 RSR</li> <li>• FZ 201</li> </ul> <p><b>GOODYEAR</b></p> <ul style="list-style-type: none"> <li>• EAGLE F1</li> </ul> <p><b>HANKOOK</b></p> <ul style="list-style-type: none"> <li>• Z209</li> <li>• Z210</li> </ul> <p><b>KUMHO</b></p> <ul style="list-style-type: none"> <li>• Ecsta V700 (inc V78)</li> <li>• Ecsta V70A</li> <li>• Ecsta TW01</li> </ul>	<ul style="list-style-type: none"> <li>• Ecsta TW02</li> <li>• Ecsta C03</li> <li>• Zeta Linea Sport</li> </ul> <p><b>MARANGONI</b></p> <ul style="list-style-type: none"> <li>• Zeta Linea Sport</li> </ul> <p><b>MAXSPORT</b></p> <ul style="list-style-type: none"> <li>• RB4 Intermediate</li> <li>• RB5</li> </ul> <p><b>MAXXIS</b></p> <ul style="list-style-type: none"> <li>• Maz1 Drift</li> </ul> <p><b>MICHELIN</b></p> <ul style="list-style-type: none"> <li>• Pilot Sport Cup</li> <li>• Pilot Sport Cup 2</li> <li>• TB 15</li> <li>• TB 15 (f &amp; r)</li> </ul> <p><b>NANGKANG</b></p> <ul style="list-style-type: none"> <li>• NS-2R</li> </ul>	<p><b>PIRELLI</b></p> <ul style="list-style-type: none"> <li>• P Zero Trofeo</li> <li>• P Zero C</li> <li>• CA67</li> <li>• CF67</li> <li>• P Zero Corsa</li> <li>• P7 Corsa Classic</li> <li>• P Zeri Torfeo R12</li> </ul> <p><b>SILVERSTONE</b></p> <ul style="list-style-type: none"> <li>• FTZ Sport RR</li> <li>• FTZ Wet Tyre</li> <li>• S575</li> <li>• S585</li> </ul> <p><b>SYRON</b></p> <p><b>TOYO</b></p> <ul style="list-style-type: none"> <li>• R888</li> <li>• R1-R</li> <li>• AO42R</li> <li>• Zestino</li> </ul>
---	---	--	---

## • 15. SAFETY EQUIPMENT

Please check the website ORCi .co.uk for current Safety Equipment regulations

## • 16. SEATS

- The driver’s seat must be secured and supported to the roll cage at shoulder level by bolting or tying.
- The 2<sup>nd</sup> roll cage cross brace may be used to support the seat, but it must be set below the bottom of the window aperture or you may construct and weld a frame on to the cage to support the seat.
- The driver’s seat must be a standard production seat, not a racing seat.

## • 17. NUMBERS

- You must fit a fin plate to the roof of your car, minimum size 18” x 12” (460mm x 300mm) and a maximum size of 20” x 15” (510mm x 380mm)
- **Fin plates must not extend beyond the end of the roof to avoid entering the car behind in the event of a jack up.**
- Your number must be either white on a black background or black on a white background, no other colours allowed, **any other writing allowed must not interfere with the numbers**, which must be minimum size 9” (230mm) high x 1½” (40mm) wide. If your number is not to the above specification, you may not be lap scored.

## • 18. ROOF GRADES

If applicable to the Promotion you race for, your grade colour must be painted on the whole roof of your car.



• **19. FINAL PREPARATION**

- Rusty or dirty vehicles will not be allowed out onto the circuit.
- Rude or provocative slogans are not allowed; please remember this is a family sport.
- In addition to the car construction rules, all cars presented at scrutineering must be considered safe and not unsightly.
- **New under sealing of the underside of the car is strictly forbidden.**



**Illustration 01**  
Valid



**Illustration 02**  
Not Valid



**Illustration 03**  
Not Valid



**Illustration 04**  
Not Valid

**901.02 Goggles/Visors**

- 901.02.01** Shatterproof goggles or a shatterproof visor **MUST** be worn with the helmet at all times.

**902 Clothing**

**902.01 Race-Suits/Overalls**

- 902.01.01** A flame resistant race-suit/overall **MUST** be worn.
- 902.01.02** Flame resistant race-suits/overalls **MUST** be manufactured from Proban®, or material of a higher specification, e.g. Nomex®.
- 902.01.03** Flame resistant race-suits/overalls **MUST** be clearly marked with the relevant SFI, FIA or equivalent standard, or the manufacturer's statement of protection.
- 902.01.04** Race-suits/overalls **MUST** be maintained in a clean and tidy condition.
- 902.01.05** Race-suits/overalls manufactured/certified to Karting standards, including, but not limited to, the CIK-FIA Level 1 or Level 2 standards, are **NOT** permitted as they do **NOT** provide the appropriate level of heat/flame protection.

**902.02 Gloves**

- 902.02.01** Flame resistant gloves **MUST** be worn.
- 902.02.02** Flame resistant gloves **MUST** be clearly marked with the relevant SFI, FIA or equivalent standard, or the manufacturer's statement of protection.

**902.03 Balaclavas**

- 902.03.01** A flame resistant balaclava **MUST** be worn.
- 902.03.02** Flame resistant balaclavas **MUST** be clearly marked with the relevant SFI, FIA or equivalent standard, or the manufacturer's statement of protection.

**902.04 Undergarments**

- 902.04.01** Flame resistant socks and undergarments provide a high degree of additional protection and are highly recommended to all competitors.

**902.05 Wet-Weather Protection**

- 902.05.01** The wearing of wet-weather protective clothing is permitted.
- 902.05.02** Any wet-weather clothing must be worn in **ADDITION** to, and **OUTSIDE** of, the required flame resistant race-suit/overall and other mandatory items specified above.

**903 Head/Neck Protection**

**903.01 All Junior Formulas**

- 903.01.01** An FHR device or neck-brace **MUST** be worn.
- 903.01.02** If a neck-brace is used, it **MUST** be of the complete-circle type, i.e. it must form a complete circle around the driver's neck with no gaps.
- 903.01.03** The use of "U" shaped, or "horseshoe" neck-braces is **NOT** permitted.

**903.02 All Adult Formulas**

- 903.02.01** The use of an FHR device or neck-brace is permitted.
- 903.02.02** The use of an FHR device or neck-brace **MUST** be in accordance with any regulations issued by the governing body for each formula, e.g. ORCi, BriSCA F1/F2, NHRPA, Stoxkarts, Individual Promotions, etc.

**904 Safety Harness**

**904.01 Usage**

- 904.01.01** A full safety harness **MUST** be used in accordance with the specifications below.
- 904.01.02** All mandated straps **MUST** be used at all times.

**904.02 Type And Design**

- 904.02.01 ALL Formulas, EXCEPT Banger Type Formulas** – The harness MUST comprise of a MINIMUM of 2 shoulder straps, 2 lap straps, and an anti-submarine strap (also referred to as a sub-strap, or crotch-strap) in a MINIMUM 5-point design.
- 904.02.02 Banger Type Formulas ONLY** – The harness MUST comprise of a MINIMUM of 2 shoulder straps and 2 lap straps in a MINIMUM 4-point design.
- 904.02.03 ALL Formulas** – The harness MUST incorporate a quick-release buckle (including rotary buckles, and NASCAR lever-latch type buckles), to which all straps MUST be connected.
- 904.02.04 ALL Formulas** – Where a NASCAR lever-latch type buckle is used, it is permitted to fit a method of protection to prevent race-suit/overall sleeves from accidentally unhooking the buckle during racing. E.g. a small section of “Tubegrip” elasticated bandage, slid over the hooked buckle.
- 904.03 Harness Strap Width – ALL Adult Formulas**
- 904.03.01 Shoulder and Lap/Pelvic Straps**  
**Applies to: ALL Harnesses (Unless Specified Below)** – The shoulder and lap/pelvic straps of ALL harnesses MUST measure at least a MINIMUM of 3in/75mm in width, unless explicitly stated below. This applies to, but is not limited to:
- ALL non-homologated harnesses
  - ALL harnesses with NASCAR lever-latch type buckles
  - ALL harnesses homologated to SFI standards
  - ALL harnesses homologated to FIA standards that do not meet the alternate FIA criteria below
- 904.03.02 Anti-Submarine Strap(s)**  
**Applies to: ALL Harnesses** – The anti-submarine strap MUST measure at least a MINIMUM of 1¾in /44mm in width on ALL harnesses.
- 904.03.03 Shoulder Straps Exception – FHR Device Use**  
**Applies to: ONLY 3in/75mm Width Harnesses Used WITH an FHR Device**  
 Where an FHR device is used by a driver, it is permitted to use shoulder straps that taper below the minimum 3in/75mm specification, above the adjuster ONLY, in order to ensure the correct fitment of the harness/FHR device combination. The lower section of the straps, between the adjuster and the tongue, must still meet the MINIMUM 3in/75mm requirement above.
- This exception applies to the shoulder straps ONLY.
  - Any such straps MUST be manufactured by a recognised industry supplier AND be specifically designed for use with an FHR device.
- 904.03.04 Lap/Pelvic and Shoulder Straps Exception – FIA Harnesses**  
**Applies to: ONLY FIA Homologated Harnesses with Lap/Pelvic Straps Less Than 75mm/3in in Width**  
 The use of lap/pelvic straps that are narrower than the generic 3in/75mm minimum width specified above is permitted on FIA homologated harnesses ONLY. The harness MUST meet ALL the following criteria:
- The lap/pelvic straps MUST measure at least a MINIMUM of 2in/50mm in width.
  - The harness MUST be certified/homologated to the current FIA standards: 8853/98 or 8853-2016.
  - The FIA identification/homologation/date labels MUST be intact and visible to scrutineers on ALL strap sections of the harness.
  - The harness MUST be within its visibly stated validity period.
  - **NO FHR Device** – If used WITHOUT an FHR device, the shoulder straps MUST measure at least a MINIMUM of 2.75in/70mm in width.
  - **WITH FHR Device** – If used WITH an FHR device, the shoulder straps MUST measure at least a MINIMUM of 2in/50mm in width, and MUST be specifically designed for use with an FHR device.
- 904.04 Harness Strap Width – ALL Junior Formulas**
- 904.04.01** The shoulder and lap/pelvic straps MUST measure at least a MINIMUM of 2in/50mm in width.
- 904.04.02** The anti-submarine strap MUST measure at least a MINIMUM of 1¾in /44mm in width.
- 904.05 Installation**
- 904.05.01** The harness MUST be securely mounted to the floor, roll-cage, and/or chassis of the racecar.
- 904.05.02** Harness manufacturers may issue their own installation guides. Therefore, harnesses MUST be installed with reference to the manufacturer’s information, and giving consideration to the mountings, and location/placement of straps in relation to other components in the racecar. Major manufacturers have installation information on their websites to aid drivers when fitting harnesses to their racecars. Useful websites include:

#### **Manufacturer's Websites**

- [www.willans.com](http://www.willans.com)
- [www.schrothacing.com](http://www.schrothacing.com)
- [www.tr3-motorsport.com](http://www.tr3-motorsport.com)
- [www.racequip.com](http://www.racequip.com)

#### **Safety Standards**

- [www.sffoundation.com](http://www.sffoundation.com)
- [www.fia.com/homologations](http://www.fia.com/homologations)

(Addresses correct at time of publication)

- 904.05.03** Key general guidelines from manufacturers for the installation of harnesses state that:
- Strap lengths should be kept as short as possible to avoid excessive stretching under impact.
  - Shoulder straps should be supported at or just below shoulder level.
  - Shoulder straps should be prevented from moving sideways, such that they may drop off a driver's shoulders under severe impact/stretching.

#### **904.06 Condition and Maintenance**

**904.06.01** Special attention **MUST** be paid to the condition of straps and fixings once installed.

**904.06.02** The harness **MUST** be maintained in good condition, and where possible kept free of dirt, oil and grease that could degrade any materials.

### **905 Window Nets**

#### **905.01 Requirement**

**905.01.01** A quick-release fabric window net **MUST** be fitted in the driver's-side door window aperture of all saloon car formulas, with the exception of Banger type formulas.

#### **905.02 Specification/Installation**

**905.02.01** The width of the netting holes must **NOT** exceed a **MAXIMUM** size of 3in/75mm wide.

**905.02.02** The window net **MUST** be fitted such that it hangs down level with the steering wheel.

**905.02.03** The window net **MUST** be flexible and easily removable, independent of any movement of the driver's-side door.

### **906 Fire Extinguishers**

#### **906.01 Requirements**

**906.01.01** A fire extinguisher, meeting the specifications below, **MUST** be carried in the driver's tow-vehicle/transporter at all times.

**906.01.02** The fire extinguisher **MUST** be within easy reach of the driver and team members at all times, especially when re-fuelling the racecar.

#### **906.02 Specification**

**906.02.01** The fire extinguisher capacity **MUST** be at least a **MINIMUM** of 2Kg.

**906.02.02** The fire extinguisher **MUST** be of a dry powder or gas type.

**906.02.03** Old type BCF (green) fire extinguishers are **NOT** permitted.

# GENERAL BANGER RACING RULES

1. All flag signals must be obeyed immediately.
1. Drivers who appear to have indulged in the intake of alcohol or drugs will be excluded from racing. Smoking is not permitted in cars, on track or in the pits at any time.
1. No passengers are allowed in the car. The driver may only travel on the car on a parade or lap of honour.
1. Banger racing is a full contact sport - drivers can race to win or attempt to win by stopping the opposition.

The Steward's interpretations and decisions on these rules are FINAL.

All heats, consolations and finals must be in one direction only. Certain Promotions allow turning around on the bends, however this does not allow a driver to drive the wrong way down the straights. It is the driver's responsibility to check with the staging Promoter exactly what rules apply at any particular meeting.

Drivers must not attack any car on the infield/safety area, or attack from the infield/safety area. An infield hit is defined when the whole car being hit is on the infield, i.e. if one wheel is still on the track, then hitting this car would be a legal hit. Again, the Stewards decision is final on this. Any serious breaches of the infield safety area rule will carry an automatic 3 month ORCi ban.

Drivers must not attack any cars after the red flag or if the stationary yellow is displayed above a car. Drivers must not attack an empty or overturned car. Any damaging collision on the driver's side between the centre of the front wheel and centre of the rear wheel will result in a penalty.

**The T-boning of cars which are against or close to the barrier with excessive force is not allowed. It is also not permitted to T-bone a car which is close enough to the barrier to mean that significant impact with the barrier is inevitable after the hit. Even where cars are not against or near the barrier, the Steward may still consider a hard T-bone anywhere on the circuit to be excessive, and may take the appropriate action to discipline the driver. The penalty for a T-boning offence as detailed above will be 3 months.**

Dangerous and/or irresponsible driving as deemed by the Steward will incur a minimum of three months ORCi ban. For avoidance of doubt, length of the straight T-bones is considered dangerous and/or irresponsible driving.

For further guidance, the following examples may also be considered as dangerous and/or irresponsible driving at the discretion of the Steward:

- Attacking a car which has been stationary for what the Steward determines to be a significant length of time.
- Attacking a car which is clearly already crippled.

Please note that repeat offences will carry additional penalties where the current ban will be double the previous ban. This means that a 2<sup>nd</sup> offence of a 3 month ban as noted above will be 6 months and then a further offence would double again to 12 months.

Using the infield or safety area in any way so as to gain an advantage is also an offence and can be punished as so by the Steward.

1. Demolition type events. Any race where the nature of the event is to stop the opposition to win the following rules apply attacking from the opposition direction is permitted providing the attack is from the outside of the track (fence side). You are also allowed to wait for car or attack any part of the car except the driver area, which is considered to be from the centre of the front wheel to the centre of the rear door driver's side.

1. Demolition Derby rules may only be used when the staging promoter declares by way of drivers briefing, letter or notice in the programme that these rules apply.
1. Drivers are not allowed to exit their cars whilst the race circuit is live i.e. under “green” racing conditions. This includes both drivers on the race track whose cars have become immobilised and those who retire to the infield who must also remain in their cars with both their safety harness and helmet on. The only exception to this is where a car needs to be vacated in emergency conditions – i.e. fire etc. If a driver is in a car and feels there is a problem which officials may not be aware of which potentially makes staying there unsafe, they should indicate this to an official with the “thumbs down” signal who will then ask race control to suspend the race. It should be noted that in all cases, the primary cause(s) of the suspension/stoppage, shall be excluded for any re-run or re-start.

If a waved yellow caution or red flag race stoppage is instigated, drivers who are already on the centre must remain strapped in and with helmets on. Drivers who are in immobilised cars on other parts of the circuit may exit their cars whilst the race is suspended but must go into a designated area which is considered by the promotion to be the safest place to be whilst the race is live, which may well be off the track completely.

1. It is an offence to put or attempt to put an overturned car back onto its wheels during a race, drivers are not allowed to re-enter a car once they have left it. Repairs are not allowed on the circuit and car must not be pushed or handled in any way during a race.
1. **A driver will be held responsible for his or her mechanics or helpers at all times.** Drivers will be bound by the decision of the officials in all matters (these two items are a condition of booking).
1. Drivers must bring his or her log book every time he or she races.
1. It is an offence for two drivers to share a car at the same meeting; you may only race one car at a meeting unless the promotion allows it as an option for special events, and with specific permission.
1. All cars, trim, glass and wheels must be removed from the stadium directly after the meeting.
1. In all events the racing must be on track indicated, drivers who try to gain advantage by corner cutting will be penalised or disqualified. Also, drivers who continue to drive on and off the safety area will be disqualified.
1. Drivers must comply with any reasonable instruction given by an official of the meeting, failure to do so will result in a penalty or disqualification.
1. Mechanics are not allowed onto the circuit or to repair any competing car. Mechanics are allowed onto the track by invitation of the Clerk of the Course or the Racing Manager only to take part in parades or lap of honour for trophy winners.

**These rules are valid from the 1<sup>st</sup> January 2024**

# **BANGERS (ROOKIES) RULES**

## **TYPE OF RACING**

- Rookie Bangers are intended to be a LIMITED CONTACT formula, BUT without excessive contact. You may push a car in front or attempt to spin it out. Drivers are not permitted to follow another car into the safety fence, intentionally attack a stationary car, drive in the opposite direction or deliberately wreck another car. Any driver who is in contravention of these rules shall at the promotions discretion receive a FULL ORC ban.
- When referring to the engine, gearbox, differential, mechanical or construction, rules and regulations the principle will always be: Unless permission is specifically granted to make modifications, or any variation, nothing may be done to alter or change in any way the standard Parts.
- Unless these rules state you can do it, you CANNOT DO IT.
- Cars found with modifications that are not permitted may result in disciplinary action being taken against the driver. All car and engine specifications will be taken from the Technical Service Data book for cars as published by Glass's Guide Service Limited.

## **1. TYPE OF CAR**

- Any British or European specification, four wheel, right-hand two wheel drive, Saloon/Hatchback or Estate car over 1300cc but under 1800cc. No Granadas or rwd Volvos are allowed except the Volvo 340 series and no cars powered by the Honda twin cam engine are permitted. The use of turbo or supercharged cars are not permitted. The car must have an all-steel body, which must not be lowered, narrowed or shortened.

## **2. PREPARATION**

- Remove all exterior mouldings/headlamps/door handles/mirrors.
- Remove all glass, interior trim, head linings, door linings, floor coverings, passenger seats. Driver's door window mechanisms must be removed.
- It is strongly advised that all possible components of the dashboard are removed.
- Remove spare wheel carriers and tow bars if fitted.
- Grilles must be removed. No replacement, "home-made" grilles allowed.
- Front wings may be trimmed to give clearance to the wheel but must not be folded.
- The B pillar should be padded to give protection to the driver's head.
- Doors must either be bolted, chained or secured with seat belt webbing. Only the driver's door may be welded, and there is no restriction on the amount of welding.
- A steel door plate 10" to 15" deep  $\frac{3}{8}$  -  $\frac{1}{2}$ " thick must be bolted over the driver's door. This must be fitted with a minimum of 3" and a maximum of 6" past the A & B pillars securely bolted with a minimum of 4 bolts. There must be at least 1 bolt through the A pillar and one must be through the B pillar or through the roll cage. The bolt size must be at least 16mm studding or bolt (Only flat plate is allowed, no channel, angle or corrugated steel allowed). 8mm is the smallest size bolt allowed on all other bolts except A & B pillar.
- No additional welding is permitted.
- Bonnet may be removable but must be securely fixed front and back with seat belt webbing or the original hinges. (No large Banger bolts or crush tubes allowed). If necessary two 10mm thread size bolts through the slam panel may be used. You are permitted to use flat plate at the rear to clip the bonnet under.
- Roof apertures must be plated over (bolted or welded) No foam filled panels
- No roof spoilers or aerofoils allowed. **Roof plates are compulsory.**
- Front and rear bumpers can be removed. All plastic bumpers must be secured using webbing. Metal bumpers may remain on providing it is the original or either Ford Focus MK1 OR MK2 to the make/model of car being used. Metal bumpers may have up to 3 extra bolts to secure fixing.
- A Ford Mondeo mk3 can be fitted with a mk1/2 Mondeo cradle.
- Roof fins must now align with the rear of the roofline, an not past.
- Uprights of the cage must penetrate both skins.
- Floor Plates are mandatory.
- One solid engine mount is permitted to silhouette the original with only 5 fixings in the engine and not more than 50mm from the block mounting face.
- Ford Focus – legs can remove the first crush zone and weld the plate back on with one inch weld on each side of the leg so bumper can be bolted back on.

### **3. SUSPENSION**

- Must remain standard. No interchanging of suspension parts is permitted.
- Brakes must remain standard and to be effective. Hand brake must be fitted and be in working order.
- Back axles must be standard to the car with no additional strengthening.
- Standard springs must be used.

### **4. ROLL BAR**

- You must fit a single “hoop” roll bar(H frame) in support of the door pillars, securely bolted to the roof and floor with a minimum size bolt of  $\frac{3}{8}$ ” (10mm thread) and suitable washers.
- The minimum size for roll bar is 2” (50mm), maximum size 4” (100mm), minimum thickness 3mm( $\frac{1}{8}$ ”).
- The roll bar cross bars must be straight, or extended forward to the B pillar and preferably bolted through the pillar
- The hoop must be one piece or two uprights on one top bar of a welded construction.
- One cross bar is compulsory, a second is optional; these must be welded or bolted to the uprights.
- Crossbars must have a 5” (125mm) square end plate fitted.
- The 2nd roll cage cross brace may be used to support the seat, but it must be set below the bottom of the window aperture THE ROLL BAR MUST NOT HAVE ANY REAR SUPPORTS but may have extensions no further forward than the B post (see diagram below). If used, these must be bolted through the B post.
- Each upright must have a minimum of two bolts on each side to the floor and one each side at the top.
- No scaffold clamps allowed, all adjustable feet must be welded to the cage.
- The seat must be supported and secured at shoulder level to the cage, you may fit the 2nd cross bar in support of the seat just below the window aperture or weld a frame on the cage to support the seat at the top.

### **5. ENGINES**

- Engines must remain on the original engine mounts.
- Air filters are free.
- All parts must be remain as manufactured within the engine type used such that the compression ratio remains standard to that engine type – i.e. the cylinder head and block must originate from the same cc of engine.
- The engine type must remain standard to the model of car used.
- Alternators may be removed.
- Sumps may be baffled to prevent oil wash away from oil pick up point.
- DRIVERS MUST BE REMINDED THAT ALL ENGINE PARTS MUST REMAIN STANDARD OR AFTERMARKET

### **6. TRANSMISSION**

- Gearbox must be as manufactured to the same model of vehicle, i.e. you cannot exchange a four speed gearbox onto an engine manufactured only with a five speed gearbox, or vice-versa..
- Axle and ratio must be as manufactured.
- No locked differentials or limited slip differentials are allowed.

### **7. FUEL SYSTEM**

- Carburettors must remain standard to the manufacturers model range. Cold start devices may be removed.
- Re-jetting is permitted.
- Single point and multipoint fuel injection is permitted.
- Electric fuel pumps may be fitted.
- The original fuel tank must be removed and replaced with a metal 2–3 gallon fuel tank with a fuel outlet at the top of the tank, with a secure screw-on metal cap, with breather pipe, which must terminate below the floor level of the car. The fitting of a one-way valve is compulsory. A fuel shut-off tap must be fitted and accessible to the driver when belted in. Fuel lines should be routed away from electrical wiring.
- All fuel lines must be in good condition and clamped.
- Flexible non-metallic fuel lines may be used to connect metal fuel pipes to carburettor and fuel tank. In all cases, fuel lines shall be securely clipped to prevent damage (or being tripped over etc).
- Only road side fuel is permitted no additives.

## **8. COOLING SYSTEM**

- Original radiators may be used in original position, or behind the engine. Bulk head steam tanks are permitted but must not come further forward than the centre line of the strut.
- Thermostat may be removed.
- No heater matrix permitted inside the car. If retained, the original matrix must be relocated under the bonnet. No other oil or water coolers permitted.

## **9. EXHAUST**

- No car will be allowed to race without an exhaust system
- The down-pipe must be standard but the rest of the system is free and must be suitably silenced. The system must terminate at the rear of the vehicle.
- All drivers must be aware that if your car is above the required noise level you will not be allowed to race. The Stewards decision is final.

## **10. ELECTRICAL SYSTEM**

- The battery **MUST** be securely clamped or bolted and can either remain in its original position or be fitted inside the car on, under or behind the roll bar **BUT NOT** in the footwell.
- It must be securely fixed, bolted down and covered with a leak/rot proof material to prevent spillage of acid.
- If batteries are secured in a box the maximum size is to be 18"x12" or equivalent.
- All wiring **MUST** be fully insulated.
- Ignition and starting must be activated through an insulated switch, not by connecting bare wires together. A battery cut off switch must be mounted on the roll cage on the near side of the car, the switch must be wired to the earth side of the battery.

## **11. WHEELS AND TYRES**

- Any standard road wheel may be used up to 6J that fits safely.
- ALL wheel nuts must be fitted.
- Hub-caps and wheel weights **MUST** be removed.
- Only conventional standard road tyres may be used up to a maximum diameter of 195mm, minimum 50 series. No competition tyres of any kind whatsoever.
- Any tyre with buffed markings will not be accepted.
- No Avon 7.3's, Avon ZB5s, Avon Turbospeed, Yokohamas, Colways (except road remoulds), Knobblies, or slicks. Note: The promotion reserve the right to review the regulation relating to wheels and tyres at any time.
- Tyres when checked by durometer must register a minimum of 60 at any time

## **12. DRIVERS SEAT**

- A seat with a head restraint must be fitted. The seat must be securely mounted at shoulder height to the cross bar or to the rollover bar and bolted securely to floor. The seat must be a standard production seat, not a racing seat.

## **13. NUMBERS**

- You must fit a number plate to the roof of your car, minimum size 18"x12" and a maximum size of 20"x15". Your racing number must be black on white background and be a minimum of 9" high by 1" wide.
- Your name must also feature prominently on the car.

## **14. GRADINGS**

- Drivers who have a roof grade in any other formula will take this roof grade in Rookie Bangers. Any driver winning a race shall start at the back of his grade for the rest of the meeting. All other drivers white tops. There is a separate points chart to that of normal Bangers.

## **15. WORLD CHAMPIONSHIP QUALIFYING**

- The top two Mendips Raceway registered drivers in the Points chart at the appropriate time will qualify for any championships within ORCi.



# **BACK TO BASICS BANGERS**

## **ELIGIBLE CARS**

- Cars must be under 1800cc petrol or under 2000cc non-turbo diesel. No Ford Mondeo, Ford Focus, Vauxhall Zafira or Vauxhall Astra are permitted. Honda powered cars up to 1400cc can be used.
- Unlimited 'Back To Basic' cars must be over 1800cc. No Ford Focus, rear-wheel driver Previa type vehicles or four-cylinder Ford Mondeo/Cougars are permitted. You may use Honda powered cars in Unlimited 'Back To Basic' meetings.

## **PREPARATION**

- Remove all exterior mouldings, screen glass, lamps, handles and any spoilers.
- Remove all airbags and charges (if fitted), interior trim & passenger seating.
- Remove the fuel tank, spare wheel carrier & tow bar if fitted.
- Remove rear spoiler and side skirts even if factory fitted.
- Remove all obsolete wiring and interior debris from the car.
- Both steel & plastic rear bumpers must be removed.
- It is compulsory to pad steering columns with high density foam if the original trim is removed.
- It is compulsory to pad the B pillar and roll cage.
- Cars must remain 'on the key' with the original ignition system.
- Petrol pumps must be able to be turned off either by the ignition key or a battery cut-off switch.
- Radiators must be left in the original position all times and replacement radiators must be in the same original place.
- Batteries may be left in the original position but if moved inside the car must be securely fastened and covered.
- Original fuel lines may be used but must enter the car either through or as near to the bulk head as possible.
- The lower edge of the front wings may be trimmed but wings must not be folded or crimped.
- Bonnets can be tied down with seat belt only in a maximum of four separate places.
- Boots/hatchbacks must be tied shut with seat belt only in two separate fixings.
- Passenger doors may be tied shut with seat belt in a maximum of two separate places which must not go through the roof or the floor. Any seat belt must be knotted and not fixed with tape or tex screws.
- No welding is permitted.
- Apart from items mentioned within these rules all other parts must remain standard as manufactured.
- You must fit a Roll bar, door plate as specified in the National Banger rules 3, 4.

## **VIOLATION**

- When referring to the engine, gearbox, final drive, mechanical or construction Rules & Regulations, the principle will always be: Unless permission is specifically granted to make modifications (or any variation) nothing may be done to alter or change the Standard Parts in any way.
- It is the responsibility of the Driver to prove to the Promotion that the part is legal, by way of written proof of where the part originated. This must be undertaken within 7 days, otherwise the item in question will be deemed illegal, resulting in immediate suspension from racing & referral for disciplinary action. Unless the rules say you can do it, you cannot do it!
- Presentation of a Vehicle for Safety Check / Scrutineering is a declaration by the entrant that the vehicle is eligible for that event.
- Car engines & fuel will be checked on a random basis. Violations or refusal to allow an engine check will result in an immediate suspension of all racing facilities.
- All Car and Engine Specifications will be taken from either the manufacturers Technical Specifications or the Technical Service Data books as published by Glass's Guide.
- Should a discrepancy occur between the Specifications then the Promotion will exercise its judgement, and that decision will be final.
- Clarification on any one item may be sought from the Promoter.
- Each driver is permitted one car per meeting & each car is permitted one driver per meeting.

## **WHEEL AND TYRES**

- Any standard manufactured road wheel may be used in any combination of sizes but this must not be used to gain an advantage.
- No tyre gaiters are permitted.
- Only conventional road tyres are allowed with the exception of any weatherspeeds, rainsport 3, or rain expert 3.
- A scrutineer has the option to ask the driver to remove any tyre they deem not within the spirit of the class.

## **VIOLATION**

- The original down pipes must be used including catalytic converter (if fitted) but silencers maybe changed but no cherry bomb type are permitted. Any car that seems to be too noisy will not be permitted to race. This is at the scrutineer and Steward Of The Meetings discretion.
- No competition type systems are allowed.
- Extra fittings are permitted.
- Ineffective or systems that become insecure while racing will require you to pull off the circuit, as you will be excluded from the results & get a black flag.

# ALTERNATOR WIRING DIAGRAM

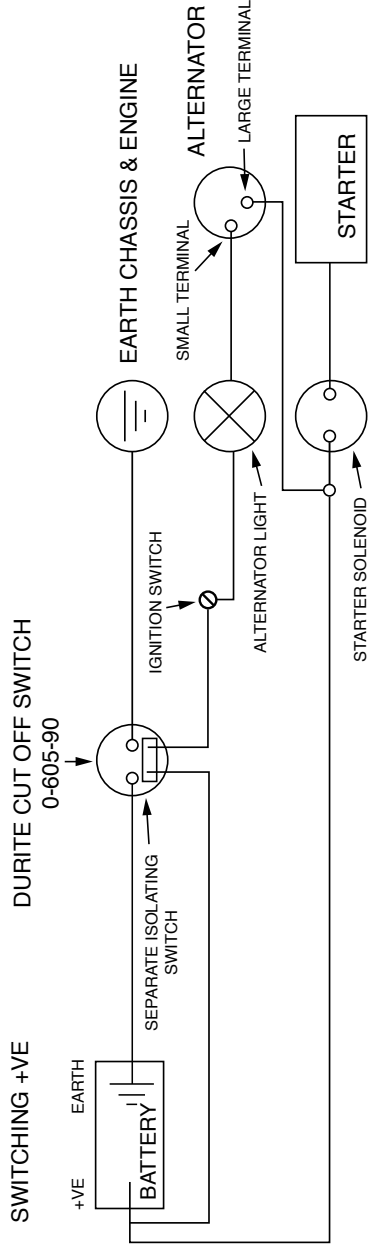
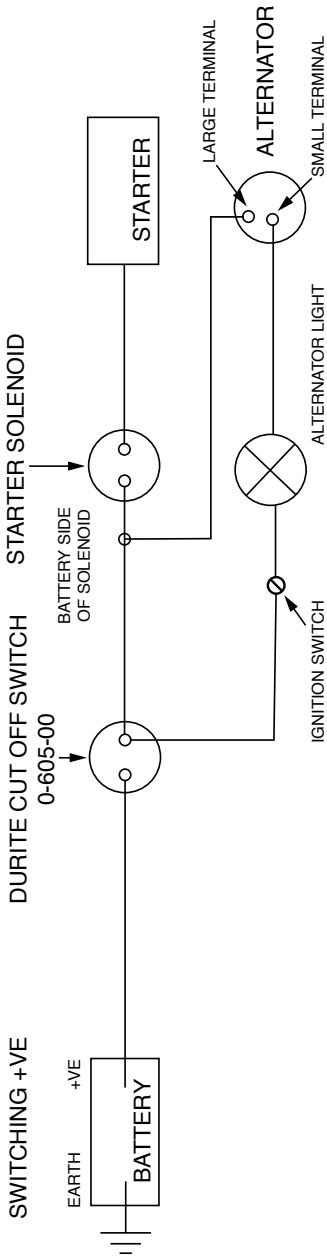



**JB Racing Race Engines for all Formulae**



*Brisca F2 / Superstox race engine*



*Full Race heads built to order*



*Meet The Team - Dan, Jamie, Chris*

**Unit 17, Charmborough Farm, Rural business Park,  
Charlton Road, Holcombe, Radstock BA3 5EX  
E mail: [jamie@jbracingmotorsport.co.uk](mailto:jamie@jbracingmotorsport.co.uk)  
Web: [www.jbracingmotorsport.co.uk](http://www.jbracingmotorsport.co.uk)**

**01761 232301 07812 542066**

## **NATIONWIDE PARTS SUPPLIER**

NEXT DAY DELIVERY SERVICE • ALL PARTS

FULLY GUARANTEED • FITTING SERVICE

**DISMANTLING 1000'S OF MODERN**

**CARS & VANS DAILY**

EXTENSIVE RANGE OF QUALITY

OFF - THE - SHELF SPARES

"FIND-A-PART" MEMBER

PERSONAL CALLERS WELCOME

### **COLIN WHITE SERVICES**

PARK FARM TRADING EST., PARK FARM RD

GLASTONBURY, SOMERSET. BA6 9NN

**TEL No. (01458) 834930**

**FAX No. (01458) 834865**

15 MILES FROM JUNCT. 23 (M5)

ENGINEERING AND ACCOUNTS TEL: 01458 833309



# **RULES AND REGULATIONS FOR SPECIAL RODS**

Special Rod racing is non contact, and designed to be a cheaper form of Hot Rod racing, using standard cars, which look like Hot Rods, with nice paintwork and professional appearance. Cars that do not meet these criteria will be failed at scrutineering.

## **1. TYPE**

The Formula is based on the Ford Sierra, Sapphire, BMW E90, E46, E36 Saloon or Coupe (but NOT compact models) using Ford engine and gearbox as detailed below.

## **2. BODYWORK**

Must be complete in all respects and unmodified externally. You may not remove the bumpers, but all glass, lamps, and trim, must be removed. You may use similar bumpers of a different make and model provided they fit neatly. Spoilers, skirts, aerofoils and the like are not permitted. All doors must be secured shut by welding or bolting but the drivers door may be left usable provided a good locking mechanism is in place. It is permitted to replace damaged doors with sheet steel of between 1mm and 2mm in thickness, to the original shape and style. Bodywork must be maintained in good order, with bright paintwork of professional appearance. Door mounted rear view mirrors are permitted.

## **3. ROLLAGE**

Must consist of a minimum of two hoops, one over the screen pillars and one over the drivers head, linked together with two longitudinal bars. Rollcages that bolt together are permitted subject to scrutineers' approval. Materials for the rollcage are 30mm minimum and 50mm maximum tube or RHS of 3mm wall thickness. Two door bars must be welded in, and it is permitted to remove the doorframe to fit these, and two bars must be welded in across the rearward hoop to support the seat, with another across the dash area welded to the front rollbar. These bars must be a minimum of 25mm tube or RHS and 3mm wall. It is permitted to add a strengthening bar on the passengers side from the footwell to the rear seat squab on 50mm tube and 3mm plate maximum, to prevent the floor collapsing on impact and save the shell.

## **4. ENGINE AND TRANSMISSION**

You may use either the 1.6l Sierra Pinto or the 1.6l Ford Zetec engine. Detail rules below:-

The engine used is the standard 1.6 Sierra OHC engine, with its original cast iron exhaust manifold, and full exhaust system. The engine may be overbored to 0.090" Nominal bore and stroke are 87.6x66.0mm (Short stroke) and 81.0x76.2mm (Long stroke) (standard size 2.0 pistons may be used in the short stroke engine). The sump may be baffled to prevent oil surge. The original carburettor must be used – either Pierburg or Weber 32/36 DGAV. Jets are free, and the original air filter may be exchanged for a performance type. Alternators are optional, but if fitted must be correctly wired and working (see page 11). The radiator must be original, and in its normal position and electric fans are permitted. No oil coolers or extra cooling systems are allowed. Any standard Ford Pinto flywheel, clutch and gearbox may be used. The flywheel may be machined, or a replacement flywheel used, to a minimum weight of 6.2kg, and only flywheels of a ferrous material are permitted. Rear axle ratio is free, and the axle may be locked, or original equipment Sierra limited slip diffs may be used. Any standard Ford Pinto camshaft may be used, with a maximum lift of 6.34mm, and adjustable vernier type camshaft pulleys are permitted.

### **ZETEC ENGINE**

The only permitted Zetec engine is the Ford 1597+1598cc 16 Valve 'Zetec (codes L1E,L1H,L1J,L1F,L1N,L1Q) with nominal bore 76.00mm and stroke 88.00mm. Or new standard uncoded Ford replacement complete engine. Production tolerances are permitted. Specifications of the Zetec Engine are further detailed below as follows:

### **ENGINE GENERAL**

Engines will be mounted upright, and aligned centre of the chassis. The use of non-standard replacement fasteners, nuts, bolts, screws, studs and washers are permitted. Gaskets are free. Any process of cleaning may be used on any component providing the surface finish, which must remain standard, is not affected.

The expression 'Standard', 'Standard production', or similar expression is deemed to imply that the part has been manufactured by Ford, or a Ford Motor Company Ltd Any machining marks on cast components resulting from manufacturing procedures will not cause disqualification. The exterior surfaces only (of the complete engine assembly) of ferrous parts may be protected by paint or similar means. Only Ford standard parts (Parts

manufactured by Ford or a Ford Motor Company authorised sub contractor) specifically for the engine codes provided can be used in this formula.

### **CARBURETTOR**

Only the standard Weber 32/36 DGV/A carburettor may be used with a maximum sized chokes of 26mm and 27mm. No polishing or re-profiling is allowed. Gaskets must be original or replicas of original (i.e. no modified gaskets). Main jets, primary and secondary jets, auxiliary venturi, and emulsion tubes may be replaced with a different size of the same part. Accelerator pump jets may be changed, but face downwards towards butterflies. Butterflies may be modified to open together, replacement spindles may be fitted with standard screws. Cold starting devices may be removed, with retaining lugs and subsequent holes blanked off. Air and fuel galleries may not be enlarged or modified; fuel may enter needle valve/float chamber from either side. Floats may not be modified or weighted, and must control the fuel flow. Needle valves may not be larger than 250, and not enlarged or modified. The power valve must be fitted in the base of the fuel bowl, but may be sealed off, and the diaphragm may be removed.

### **CYLINDER BLOCK**

It is not permitted, as means of repair, to replace damaged cylinder bores with cylinder liners. The crankcase breather may be modified, including removal, as long as no air and/or oil escape from this area other than through pipe-work to the catch tank. Pistons must not protrude above block deck face at any point. Standard oil dipstick tube and dipstick must be fitted. It is not permitted to remove or modify the four standard oil spray jets. Overboring is not permitted.

### **OIL PUMP**

It is not permitted to modify the standard Ford oil pump/front cover in any way.

### **CYLINDER HEAD (INCLUDING VALVES AND VALVE GEAR)**

No work that removes, adds, replaces, or transfers material is allowed on the cylinder head with the following exceptions.

- Simple cleaning which does not alter in any way the shape of the component.
- Minimal material removal from the head face to correct combustion chamber volume and/or reclaim head flatness.

The cam cover assembly cannot be modified or replaced.

The oil filler cap shall be sealed by spring/lock wire or similar.

All valve train components must remain standard.

Valves must remain standard Ford supplied items, no re-profiling or polishing is permitted.

Standard valve stem seals must be retained.

### **CAMSHAFTS AND PULLEYS**

The only permitted camshafts are the standard production camshafts from any Ford Zetec E 'Silvertop or Blacktop' with the Original Ford casting ring identification marks. Camshafts can be interchanged between silvertop and blacktop but you must use a matching pair (not one silvertop and one blacktop and you must use the correct cam in the correct position, i.e inlet cams can only be used on the inlet side exhaust cam on the exhaust side etc . The camshafts must remain entirely unmodified. It must be fully manufactured and ground by the Ford Motor Company. It is prohibited to grind from blanks, re-grind or re-profile. Only the production surface finish is permitted. Shot peening, shot blasting, surface treatments or polishing are prohibited. The only permitted camshaft drive pulleys are the standard Ford items. The cam drive pulleys may be keyed to the camshaft by dowel only. The sprung loaded cambelt tensioner may be locked or replaced with a fixed item. Vernier Pulleys are to be permitted for use on Zetecs.

### **CONNECTING RODS**

Connecting rods must be standard. Machining/grinding is not permitted to remove metal from the connecting rod or cap. Polishing is prohibited. Connecting rod bolts are free subject to them remaining in ferrous material.

### **PISTONS**

Pistons must be standard production pistons unmodified in any way.

### **CRANKSHAFT**

A standard crankshaft must be used. Crankshaft journals must remain within Ford positional tolerances if a repair re-grind is carried out. Additional drives to the water pump may use this pulley, or extra pulleys mounted in front of the crankshaft damper. The crank journals may be re-ground for reclaim. Standard oversize and undersize bearings are permitted.

## **FLYWHEEL AND CLUTCH**

A standard crankshaft must be used. Crankshaft journals must remain within Ford positional tolerances if a repair re-grind is carried out. Additional drives to the water pump may use this pulley, or extra pulleys mounted in front of the crankshaft damper. The crank journals may be re-ground for reclaim. Standard oversize and undersize bearings are permitted.

## **SUMP AND PICK UP PIPE**

Oil sump and oil pick up pipe are free. It is permitted to remove a section of the front crossmember to use the Mondeo sump.

## **OIL FILTER**

Oil filters are free.

## **OIL COOLERS**

No oil cooler is permitted.

## **COOLING SYSTEM**

A water based liquid cooling system is mandatory. The standard production water pump and housing must be retained, although drive to the pump, its rotational speed and direction may be changed. The radiator and associated pipes are free. No other pump may be used to circulate or assist circulation of the coolant liquid. Thermostat housing is free.

## **ENGINE IGNITION CONTROL UNIT (ECU) AND ELECTRICAL**

The only means of ignition will be by use of Ford crankshaft speed sensor fitted to the standard manual sensor housing and Ford based ignition coil. No other sensors engine or chassis permitted. Ignition Control Unit (ECU) is free. The coil unit may be re-positioned. The HT leads to the sparking plugs are free. Sparking plugs are free, provided they fit the engine without any modification to the cylinder head or the sparking plug and that the sparking plugs place the spark gap in the same position as the production sparking plug within the combustion chamber.

## **INLET MANIFOLD**

Any fabricated inlet manifold can be used, including any adaptor plates required to mount manifolds from other 'Ford' engines.

## **EXHAUST**

An original Ford Zetec Manifold to be used, with the remainder of the system to be free to suit ease of fit.

## **5. WHEELS AND TYRES**

**Sierra:-** Any original manufacture wheel to be used ie Ford/Peugeot, either steel or alloy, to a maximum of 7J. The only tyre permitted is the Yokohama BluEarth ES32 in either 175/70R13, 185/65R14 or 195/50R15.

**BMW:-** cars must use the standard wheels to what the car is manufactured, whether steel or alloy, If the car is made with a 16" wheel, you must use a 16" wheel. All 4 wheels must be either steel or alloy not 2 & 2. Tyres permitted only are Yokohama Blu Earth ES32 in either 195/50R15, 205/45R16 and 205/40R17

## **6. SUSPENSION AND STEERING**

**Suspension:-** All original and standard components must be used, no adjustable shocks, coilovers or Leda, Springs are free. All suspension must be in its original position using the original mounting points and not modified in anyway.

**Sierra:-** (Front) The offside bottom arm may be modified, the anti-roll bar may be modified to suit. Negative camber on the nearside front wheel is permitted but not adjustable. This may be achieved by re-drilling the cross member, Anti-roll bars may be modified to suit. (Rear) The components are to be standard & original in length, but may be upgraded. No adjustable parts, fixed or otherwise are allowed. No other modifications are allowed. No competition parts. Suspension may be lowered. Negative camber may only be achieved by shimming the drive shaft location.

**BMW:-** (Front) Negative camber can only be achieved by moving the top mount or the use of camber plates; however these must be fixed via welding once set in place and non adjustable. Anti-roll bar must remain standard if using it or it can be fully disconnected. (Rear) You may achieve negative camber by modifying the back arm/arms but must be welded and not adjustable on the passenger side only. This does not include the

adjustment which is standard from manufacturing.

**Steering:-** Sierra - The Steering rack must occupy its original position, & manual racks can replace PAS systems. Quick racks can also be used. The steering rack arms may be modified: Nearside rack arm may be lengthened, the Offside may be shortened.

BMW models must remain standard. The steering column height may be adjusted & reinforced at the top bracket.

## **7. BRAKES**

Must be in working order, including handbrake, and no modifications made for bias braking.

## **8. FUEL SYSTEM**

The original tank must be removed and replaced with a 2 gallon maximum capacity tank fitted within the area covered by the rollcage, and isolated from the driver by a metal firewall. Fuel feed and vent pipes must exit from the top of the tank – gravity fed tanks are not permitted and the vent pipe must be fitted with a one way valve. The fuel tank filler cap must be of a metal screw type. All fuel pipes must be metal, with 6" maximum flexible connecting pipes, and a shut off tap fitted within reach of the driver when strapped in his seat. Electronic Fuel pumps are permitted.

## **9. ELECTRICAL SYSTEM**

The battery must be fully enclosed in a leakproof compartment or frame and bolted to a strong part of the car away from the driver. A battery cut off switch must be fitted to the rear left windscreen pillar and clearly marked (see page 11). All wiring must be securely clipped and correctly routed. Two rear facing red brake lights must be fitted in the rear window aperture.

## **10. SEAT AND SAFETY HARNESS**

The seat must be securely fitted and preferably a bucket type with head support. A full racing harness of four separate straps must be fitted with solid mountings and backing plates, and 10mm dia bolts minimum.

## **11. FINAL PREPARATION**

The drivers racing number must appear on both sides of the car prominently painted 12" high. It must also be on a roof fin plate Black on White 9" high both sides. The drivers name must either be on a windscreen visor, or on the bonnet or offside of the car in letters of 6" high and clearly visible. The whole roof of the car must be painted in grading colour to the gutter line.

## **12. GRADING AND STARTING POSITIONS**

Drivers will be graded based on points scored per weekend raced. Drivers will be upgraded and downgraded per weekend, one grade at a time. Final winners will go up a grade on a weekend with two race meetings. Any driver not racing will not be downgraded and will return in the grade held before retirement. In the Final, a draw may be carried out within grades for starting positions but heat winners will start the Final at the back of their grades. Day licenses are available, but a £100 bond must be paid and will be returned pending good behavior. Day license drivers must start at the rear of the grid. A ban can be issued for life if rules are broken.

## **13. LAPSCORING AND TESTING**

Lapscoring will be by electronic means using the Just Timing system, and all cars must be fitted with a transponder. These are available from the Office @ £70 plus VAT. Any driver wishing to test experimental parts with permission will not receive points.

## **14. ALLOCATION OF HEATS**

Depending on the number of cars available, heats will be run as A) two heats, consolation and Final, or B) 2/3 heats and all in Final, or C) all cars in all races. The number of cars per Final may be restricted. Points will be awarded in meeting type A) as 10-1 in heats, 4-1 in the Consolation, and 20-2 in the Final, and in meeting type B) and C) all races will carry 10-1 points. West of England Championship will be a randomly drawn grid, with a reverse grid for the next heat or two heats and a consolation depending on numbers. The Final will be decided on points scored through the heats.



# **RULES FOR JUNIOR RODS**

## **1. TYPE OF VEHICLE**

Any saloon car or hatchback car of less than 1000cc fuelled by carburetor or single point injection of a four cylinder 8 valve configured engine no 16v permitted. The steering and suspension must remain standard to the year of manufacture of the car used and not include any post manufacture upgrades.

## **2. PREPARATION**

The car must be stripped of all glass, lights, exterior and interior trim. The bodywork must be all steel and complete, with no steelwork cut away, and no aerofoils sideskirts or similar added. The doors can be welded shut, or closed with an approved locking device. A rollcage must be fitted consisting of two hoops – one over the screen pillars and one over the drivers head joined at the top with two longitudinal bars, with at least one drivers door bar, and a crossbar behind the seat, all made from round tube or box of 30mm x 3mm wall minimum. Plates must be welded to the bottom of rollcage pillars to strengthen them if the floor is rusty or damaged. Aluminium rollcages are not permitted. Scaffold clips are not allowed and all steelwork must be inside the car. The bodywork must have a smart appearance, and must have the drivers racing number painted black on white on both sides of the car 11" high and on a roof fin 9" high. The drivers name must be on the nearside of the car on the roof or on a screen panel 4" high. Grading colours must be painted either on the whole roof or in two 9" strips on the roof. Two braking lights (not led) must be fitted in the rear parcel shelf. No modifications are permitted to suspension or steering components. It is not permitted to weld plates over the headlamp apertures, and bumpers may be removed, or original bumpers only retained. Both door mirrors must be retained.

## **3. SAFETY EQUIPMENT**

A full racing harness consisting of four or five straps must be fitted, with a quick release buckle. Great care must be taken to ensure the drivers seat back height is not such that the straps may fall off the drivers shoulder, and straps may be looped together at the top of the seat to prevent this. The shoulder straps must be fitted to the floor or the rear seat squab, not the parcel shelf and all mountings must have substantial backing washers and be in areas free of rust. Strong suitable boots or shoes must be worn-no trainers. A forward head restraint system must be used, either in the form of a Hans type devise, or a substantial high density foam neckbrace.

## **4. ELECTRICAL SYSTEM**

The battery may be retained in its original compartment, with an improved strap, and fully covered, and a cut off switch connected to the earth circuit mounted in the nearside (passenger side) rear side window aperture. It is important to remove all of the original wiring loom. Steering locks must be removed. Switch operation must be indicated by paint or ORC sticker that can be provided by the Scrutineers.

## **5. FUEL SYSTEM**

Fuel tanks are to be made of metal and of 2 gallons capacity maximum, with a screw cap, and the fuel pipe and breather must exit the tank at the top. A one way valve must be fitted to the breather. Take care to fit it securely in the boot as far from the battery as possible. The fuel line must be metal, and run inside the car, with flexible link pipes of 6" length maximum, and a suitable fuel tap within reach of the driver when strapped in the seat. With single point injection cars, external or submersible pumps are allowed, and the fuel pump must be wired to stop when the ignition switches off. Electric or manual fuel pumps may be used. All cars must be fitted with a flat metal restrictor plate minimum of 3mm thick between the carburetor and manifold with one hole 18mm diameter drilled in the centre of the plate, which may not be chamfered, or dished or polished in any way. The restrictor plate fitments is free above or below any spacer plate. However it must not touch, interfere or restrict any of the carbs operations including choke flaps. If a water filled inlet manifold is present the restrictor plate is permitted to prevent the flow of water and any old pipe work can be removed/blanked.

## **6. WHEELS AND TYRES**

Only standard wheels as originally fitted to the car may be used, either steel or alloy, and must be the same size on all four corners of the car. All cars except Minis must use 13" wheels, and the maximum width of tyres may be 1.55 and the minimum profile 70 aspect. All tyres must be standard road pattern and design. Wheel spacers are not permitted. On each axle the wheels must be matched in type; ie alloy or steel & have the same width & offsets.

## **7. MINI ENGINE & GEARBOX SPECIFICATIONS**

These rules apply to Minis. For all engines, alternators the original engine must be fitted either 850cc or 998cc. Engine numbers must be present on the cylinder block- 99H for the 998cc engine. The Mini A Plus engine is permitted but not the Metro A Plus. Standard carburetion and manifolding must be used and air filters fitted. Cylinder head casting number are:- 12A 1456, 2A 629 and CAM 4810. Cylinder bore is 2.508" and stroke 3.005" maximum. Alternators and dynamos are optional, but if fitted must be working. No modifications to improve the engine performance are permitted, all ancillaries must be in place, and standard gearbox and transmission must be used. The original complete exhaust system must be in place. It is permitted to modify the oil pickup pipe. Electronic ignition is permitted. Standard carburetion and manifolding must be used, air filters are compulsory but free. Ask the scrutineer for details. Engine swaps are allowed on Micra, Corsa, Fiesta, Seicento and Saxo ,providing these are using earlier engines in later shells, but must be of the same manufacture.

## **8. ENGINES & TRANSMISSIONS**

All engines & gearbox components must remain standard ie no machining, polishing or removal of material is permitted on any parts. Clutches must remain standard. It is not permitted to run a limited slip differential or locked/welded differential.

## **9. LATER CAR SHELLS, ENGINE SWAPS, SUSPENSION**

Engine & gearbox swaps are permitted in order to use later car shells ie Micra, Corsa, Fiesta, Seicento, Saxo providing theses are using earlier engines in later shells, but the engine and gearboxes must be of the same manufacturer. The suspension must remain standard to the later shell used.

## **10. AGE LIMIT**

Junior Rod drivers may start racing on their eleventh birthday, and must retire on their sixteenth birthday or before. A copy of birth certificate must be provided to the Office before the Licence is issued. Novice drivers must paint a black cross on the bootlid, and may start at the back of the grid for three meetings. A driver whose 16th birthday falls during the racing season may, provided he or she has completed two full seasons of racing, opt to go into an adult formula in that season.

## **11. GRADINGS**

Driver will be graded according to points scored and gradings issued at regular intervals throughout the season. Driver achieving star grade may not drop below blue. The whole roof of the car must be painted in the grading colour. Season points will determine the grid for West of England Championship, with a minimum of 5 meetings attended needed to be in the Championship Race.

The Scrutineers have the right to reject cars that are unsafe, or which have excessive body damage. If a car is failed at Scrutineering, you have the right of Appeal to the Steward.

## **12. ABILITY TEST**

All new drivers must take an ability test before they are allowed to race. This will not normally take place on race day, due to lack of time. Phone the office for details. Please do not arrive at the track without contacting the office in advance. The promotion reserves the right to stop any driver from racing if he/she cannot achieve a minimum lap time, which makes them a danger to other drivers.

## **13. SAFETY**

Junior Rod drivers must be made aware of the dangers of driving cars in restricted areas. No passengers may be carried in or on the car except during parades, and parents must supervise the unloading and loading of cars, preferably doing so them selves. Cars must not be driven around the pits except when lining up for, or returning from races, or scrutineering. To prevent the scramble for grid places in pit lane, the grids for the heats may be printed in the programme.

## **14. POINTS**

Depending on the number of cars available, heats will be run as A) two heats, consolation and Final, or B) 2/3 heats and all in Final, or C) all cars in all races The number of cars per Final may be restricted. Points will be awarded in meeting type A) as 10-1 in heats, 4-1 in the Consolation, and 20-2 in the Final, and in meeting type B) and C) all races will carry 10-1 points. The West of England Championship Final carries double points.

## **15. RACE RECEIVERS**

Race receivers must be worn and fully functional to the correct frequency of 952 by all drivers in all races.

# **RULES FOR RELIANT ROBINS**

## **1. DEFINITION**

Reliant Robin racing is a light contact, fun formula, the object of which is to complete the number of laps specified in the shortest time. Gentle nudging and side contact is allowed, but no deliberate ramming or heavy contact.

## **2. TYPE OF CAR**

You may use any 3 wheeled Reliant Robin, Regal or Rialto.

## **3. ENGINES**

No engine modifications are permitted with the exception of replacement of the air filter and removal of the alternator. Cooling may be by conventional radiator, or by a water tank of a reasonable size, provided it is contained within the engine compartment.

## **4. ROLL CAGE**

The minimum requirement is a full cage with two hoops, one behind the driver and one in support of the front windscreen pillars with two longitudinal bars, one each side joining the two hoops together. A minimum of one chicken bar in each door is required fitted between the front and rear pillars, minimum size material is 1½" box or tube 3mm thick, all roll cages must be bolted or welded on to the chassis, Roll cages must terminate within the silhouette of the car, rear supports must end no further back than the end of the chassis. No external hoops allowed on the roof. It is compulsory to fit a roof plate covering the area of the drivers seat, maximum 6mm plate. Door plates may be fitted, but must be inside the car, and also 6mm maximum. **Roll bars must be contrasted of 40mm box or tube minimum. Steering box guards are to be permitted.**

## **5. FUEL SYSTEM**

The original petrol tank must be removed and replaced with maximum size 2-gallon safety tank fitted inside the car, either on, under or behind the roll bar bolted to the Roll Cage or the chassis. The fuel outlet must be from the top and the tank must have a breather pipe fitted with a one way valve. A fuel tap must be fitted within easy reach of the driver all fuel lines must be secured.

## **6. ELECTRICAL SYSTEM**

It is permitted to fit two batteries for 24v starting, of maximum Sierra/Cavalier size (eg065), and wherever fitted, must be fully covered or boxed to avoid acid spillage. Electronic ignition may be used if fitted as original equipment.

## **7. WHEELS, TYRES, SUSPENSION & AXLES**

**The car must be fitted with wheels of original size and width according to the model, with alloy replacements permitted. Only one wide wheel is permitted. Maximum tyre size is 165x70 profile, and all tyres must be road legal conventional tyres and not competition type. The only permitted suspension modification is to lower the nearside rear spring by heating. The rear axle may not be offset, and welded or limited slip diffs are not allowed. Front suspension arms may be strengthened by welding on two pieces of 50x50mm angle iron, with a secondary fixing permitted, and damaged front crossmembers may have one piece of tube of maximum wall thickness 5mm inserted into it. Diff guards are also permitted.**

## **8. SAFETY EQUIPMENT**

A full shoulder type safety harness comprising of two shoulder straps and two lap straps must be used the use of a sub strap is optional. A suitable head restraint must be used fitted to the cage or the seat. The driver seat must be secured to the roll-cage at shoulder level by tying or bolting.

## **9. FINAL PREPARATION**

Remove all trim, windows and seat except the drivers, this may be replaced with a suitable competition seat or any standard seat from an other car. Remove all glass except the inside mirror, wheel trims, fuel tanks and furry dice. Cars must be in good condition at the start of a meeting and brightly painted. Cars with damaged bodywork will be allowed to race, subject to scrutineer's approval.

# MENDIPS Raceway

Thunder in the Hills!

## Racing Fixtures 2024 Season

Sat Jan 27<sup>th</sup>

Mendips Raceway Presentation evening

Sat Mar 2<sup>nd</sup>

Practice Day 10 am-4pm

Sun March 17<sup>th</sup>

Bangers Down West 1600 Smash ● Junior Rods ● Heritage F2

Sun March 31<sup>st</sup>

Brisca F2 Stock Cars World QR Gerry Dommert Memorial Trophy  
● Special Rods ● Saloons Stock Cars Master of the Mendips sponsored by  
'Uncle Bods Tyre Shack

Mon April 1<sup>st</sup>

Banger Vans-diesel only-Ramplins Trophy including Destruction Derby!  
● Special Rods ● Junior Rods ● Robins

Sun May 5<sup>th</sup>

Rookie Bangers ● Junior Rods ● Special Rods

Mon May 6<sup>th</sup>

Unlimited Old Skool ● Brisca F2 Stock Cars ● Robins Crazy Day

Sun May 26<sup>th</sup>

Brisca F2 Stock Cars ● 2l National Bangers (PRI Wildcard) ● Junior Rods

Mon May 27<sup>th</sup>

Robin Caravans, Special Rods ● Rookie Bangers

Sat June 29<sup>th</sup>

Mendips Mayhem Weekend! Unlimited Bangers Thunderbolt 24  
● National 1600 Bangers ● Back to Basics Caged Open

Sun June 30<sup>th</sup>

Small Van Bangers, Mendips Mayhem Weekend B2B u1800cc ● Robins

Wed July 24<sup>th</sup>

Rookie Bangers ● Special Rods (Summer Series R1) ● Robins, ft Caravan  
Long Jump

Wed July 31<sup>st</sup>

Brisca F2 ● Junior Rods ● Stock Rods

Sunday Aug 4<sup>th</sup>

Rookie Bangers Filo's Crashmania Team Meeting ● Brisca F2 Pink Ribbon  
Trophy ● Special Rods

Wed Aug 7<sup>th</sup>

Unlimited Old Skool ● Robins ● ORCi MiniStox

Wed Aug 14<sup>th</sup>

Rookie Bangers ● Special Rods(Summer Series R2) ● Drifting

Wed Aug 21<sup>st</sup>

B2B Micro Bangers ● Junior Rods ● B2B Hare and Hounds ● Caravan Race

Sun Aug 25<sup>th</sup>

1600cc National Bangers ● Brisca F2 Stock Cars Marion Bennet Trophy  
● Junior Rods

Mon Aug 26<sup>th</sup>

Rookie Bangers CARAVANDALISM 24 ● Special Rods Summer Series R3  
● Robins Figure of Eight including Destruction Derby!

Sat Sept 21<sup>st</sup>

V8 Hotstox Championship of the World 2024 ● Special Rods Summer  
Series Finale ● ORCi Ministox

Sun Sep 22<sup>nd</sup>

National Banger Championship of the World 2024 ● Saloon Stock Cars  
● V8 Hotstox

Sat Oct 26<sup>th</sup> - 3pm

Halloween Havoc! Rookie Bangers West of England Championship  
● Junior Rods West of England Championship ● Special Rods West of  
England Championship including the 2024 Firework Finale!  
● Pre - Meeting Halloween Parade and Meet and Greet - 3pm start

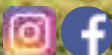

All meetings start at 1.00pm unless otherwise stated